

mySigen App User Manual

Version: 13

Release date: 2026-04-14



Copyright Notice

Copyright© 2026 SigenergyTechnology Co., Ltd. All Rights Reserved.

Description in this document may contain predictive statements regarding financial and operating results, product portfolio, new technology, configurations and features of product. Several factors could cause difference between actual results and those expressed or implied in the predictive statements. Therefore, description in this document is provided for reference purpose only and constitutes neither an offer nor an acceptance. Sigenergy Technology Co., Ltd. may change the information at any time without notice.



SIGENERGY

and other Sigenergy trademarks are owned by Sigenergy Technology Co., Ltd.

All trademarks and registered trademarks in this document belong to their owners.



Website



LinkedIn



YouTube

www.sigenergy.com

Contents

Revision History	05
Overview	07
Chapter 1 Installing and Login	08
Chapter 2 Information querying	11
2.1 Station Information	11
2.2 Sigen Inverter/Battery Information	13
2.3 Sigen EV AC Charger information	14
Chapter 3 Service Page Information	18
Chapter 4 System Settings	19
4.1 Energy management settings	19
4.1.1 Operational mode	19
4.1.2 Manual Control	29
4.1.3 Power station energy configuration	30
4.2 Energy Saving Mode	45
4.3 General setting	46
4.4 Troubleshooting	49
4.5 System Maintenance	50
Chapter 5 Main Device parameter setup	52
5.1 SigenStor/SigenStack Unit Settings	52
5.1.1 Remote Connectivity of the Device	53
5.2 Sigen EV DC Charging Module Setting	55
5.2.1 (Optional) V2X Function Settings	57
5.3 Sigen EV AC Charger	58
5.3.1 Sigen EV AC Charger activates Sigen AI Mode	65
Chapter 6 Add Sigen/Third-Party Device	66
6.1 SigenMicro	66
6.2 Smart load	67
6.3 Grid-side Sensor	74
6.4 Generator	76

6.5 Third-party inverter	79
6.6 SG heat pump	83
6.7 AndSolar	86
6.8 Environmental Monitor	87
Chapter 7 Account Setting	88
Chapter 8 Setting&Tools	89
8.1 Local Connection	90
Chapter 9 Logout	93
Chapter 10 FAQs	94

Revision History

Version	Date	Description
13	2026.04.14	Updated Operational mode Updated General setting Updated Smart load Updated Grid-side Sensor Updated Setting&Tools Updated FAQs
12	2026.02.09	Updated Installing and Login Updated Service Page Information Updated Grid Settings Updated Backup Setting Updated General setting Added Remote Connectivity of the Device Updated Smart load Updated Grid-side Sensor Added Environmental Monitor Updated Setting&Tools Added Local Connection Updated FAQs
11	2025.12.18	Updated Troubleshooting Updated Operational mode Updated Battery Settings Updated Grid Settings Updated General setting Updated Smart load Updated FAQs
10	2025.11.05	Updated Battery Settings Updated SigenStor/SigenStack Unit Settings Updated Sigen EV DC Charging Module Settings Updated Sigen EV AC Charger Settings Updated Add Sigen/Third-Party Device Added Sigen Micro Updated FAQs
09	2025.09.26	Updated Station Information Added Troubleshooting Updated Sigen Inverter/Battery Information Updated Smart load Updated Grid-side Sensor Updated Generator Updated Third-party inverter

Version	Date	Description
08	2025.08.22	Updated Grid Settings Added AndSolar Added Grid-side Sensor Added (Optional) V2X Function Settings Added (Optional) Sigen EV AC Charger activates Sigen AI Mode Updated FAQs
07	2025.07.29	Updated Station Information Updated Operational mode Updated Manual Control Updated Solar Settings Updated Backup Setting Updated Smart load Updated Sigen EV DC Charging Module Setting Updated FAQs
06	2025.06.11	Added Energy management settings Added General setting Updated Smart load Updated Main Device parameter setup
05	2025.03.10	Updated Operational mode Updated Add Sigen/Third-Party Device Updated Sigen EV DC Charging Module
04	2024.10.11	Updated Operational mode Updated Add Sigen/Third-Party Device Added Main Device parameter setup
03	2024.05.17	Updated Information querying Updated Operational mode Added Add Sigen/Third-Party Device
02	2024.01.15	Updated Information querying
01	2023.09.11	Initial release.

Overview

Introduction



This document describes how to use the mySigen App.

Readers

This document is intended for: Users

Sign Definition

The following signs may be used in the document to indicate security precautions or key information. Before installation and operation, familiarize yourself with signs and their definitions.

Signs	Definition
 Danger	Danger. Failure to comply will result in death or serious personal injury.
 Warning	Warning. Failure to comply will result in serious personal injury or property damage.
 Caution	Caution. Failure to comply will result in property damage.
Tips	Important or key information, and supplementary operation tips.

Chapter 1 Installing and Login

Tips

This document takes version 3.5.0 as an example to introduce relevant operations. The screenshots given in this document are for illustration purposes only. Interfaces in different periods may differ. The actual interface display shall prevail.

Downloading the App

Tips

Mobile operating systems: Android 6.0, iOS 12.0, and later versions.

You can download the App using the following two methods:



Owner account registration

Tips

Method 2 registration is supported in certain regions. Please refer to the actual display in the App.

Method 1:

1. Provide your email account to the installer for signing up.
2. After signing up your account, the installer will ask you to activate your account.
3. Please check the email sent from the "sigencloud" account in your inbox, set your initial password, and activate your account.

Method 2:

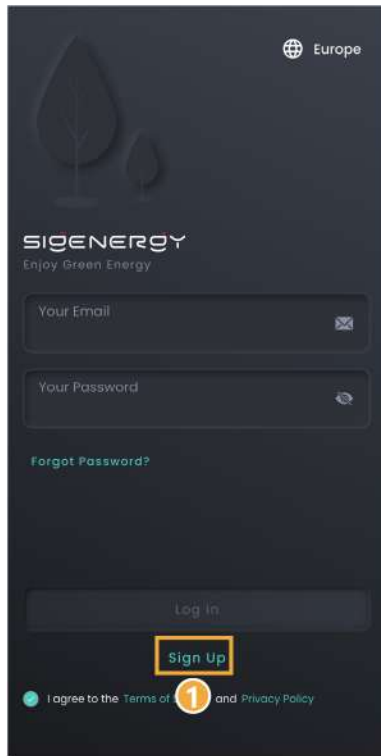

MSA1SF00001

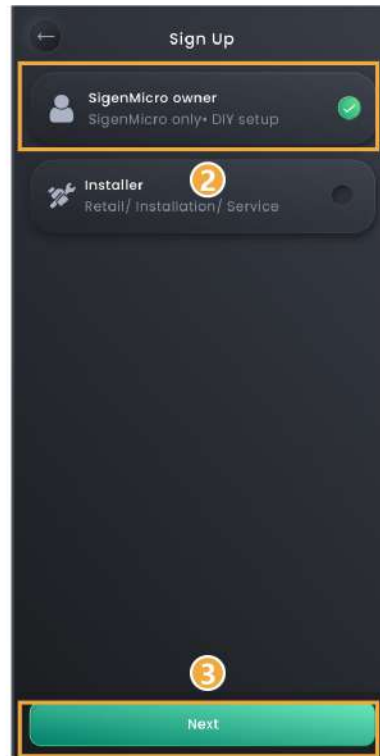

Login:

Enter your account and password and click "Log in".



SSA1CM00002

Creating new system for the device

Tips

Only Sigen Micro power stations with power specifications that comply with local regulations support owner-initiated commissioning.

Scenario without other system:

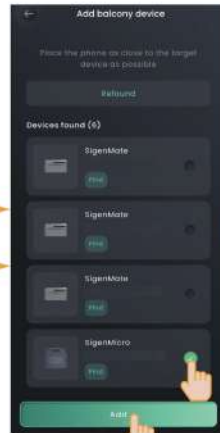

Scenario with other system:

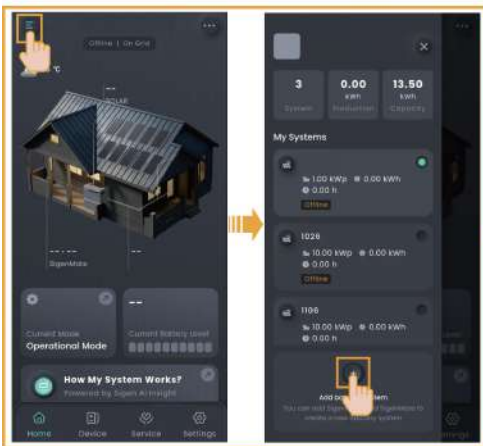

MSA1CM00093

Chapter 2 Information querying



2.1 Station Information

Operation Information





MSA1CM00068

Share Power Station

The Home screen displays running information, You can click  →  to share information displayed on the Home screen to others.

Homepage Customization Settings

- Click  →  to create a customized homepage layout according to your needs.
- Click 'Restore Defaults' to reset to default settings.

Power Station Page House Style Modification

- You can set the house style displayed on the homepage according to your needs.
- The 3D house style requires downloading before use.



MSA1CM00071

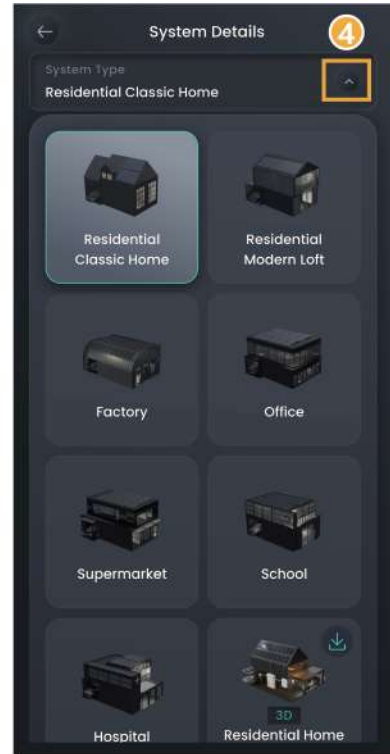
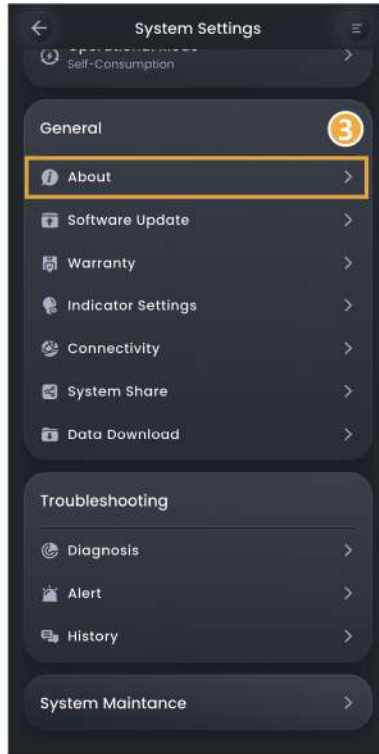

Energy Analysis

Click the energy box to view the energy flow.



MSA1CM00068

2.2 Sigen Inverter/Battery Information

Tips

- When multiple Singrow inverters/batteries are connected to the same power station, swipe left/right or up/down to view each Singrow inverter/battery.
- The SN number displayed in the App matches the SN number on the Singrow inverter/battery label. You can locate the specific Singrow inverter/battery you need to view by its SN number.



MSA1CM00069

2.3 Sigen EV AC Charger information

Go to the corresponding interface using the following method, and click "Energy Delivery" to view detailed information.

Pure charging application

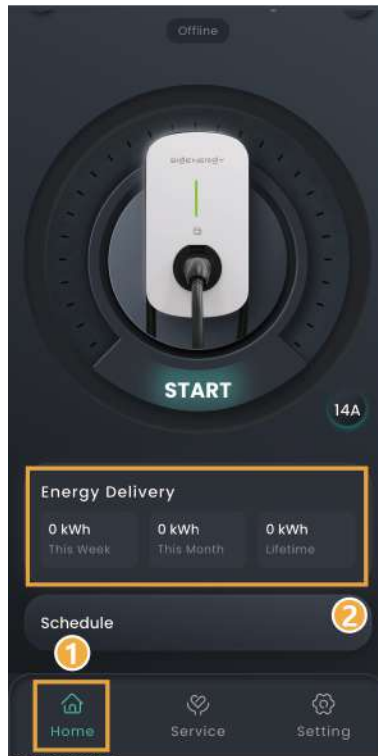

MSA1CM00075

PV charging or PV storage & charging application

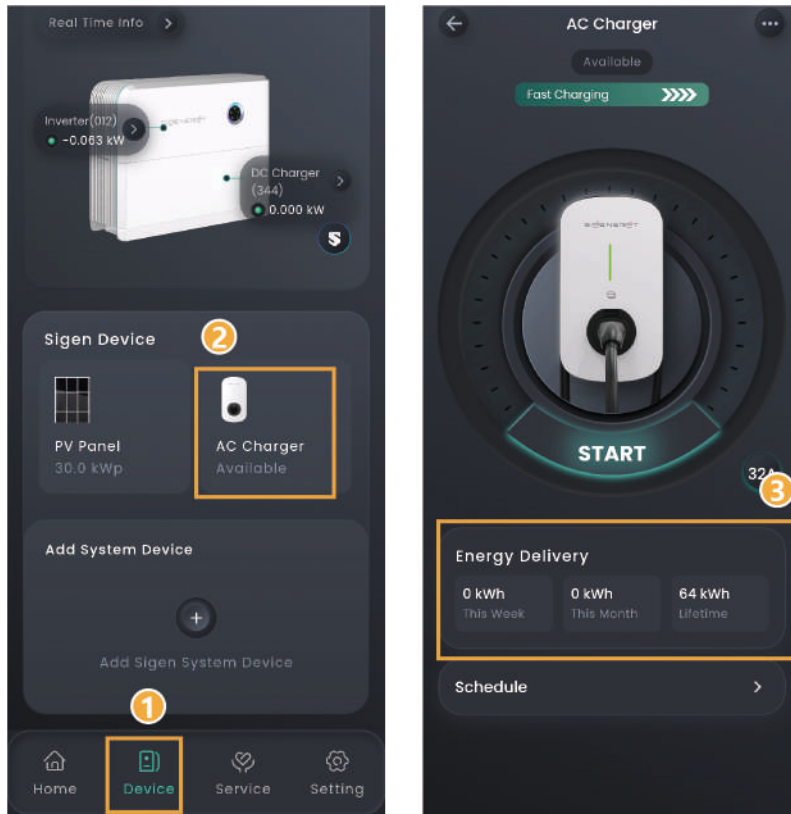

SSA1CM00070

Alarm information

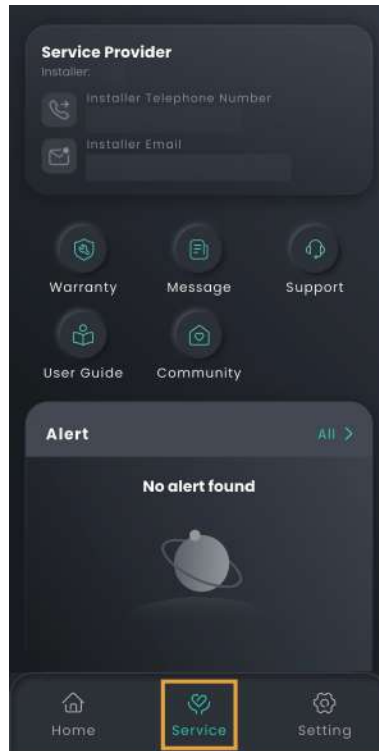

MSA1CM00075

Charging Records

Pure charging application

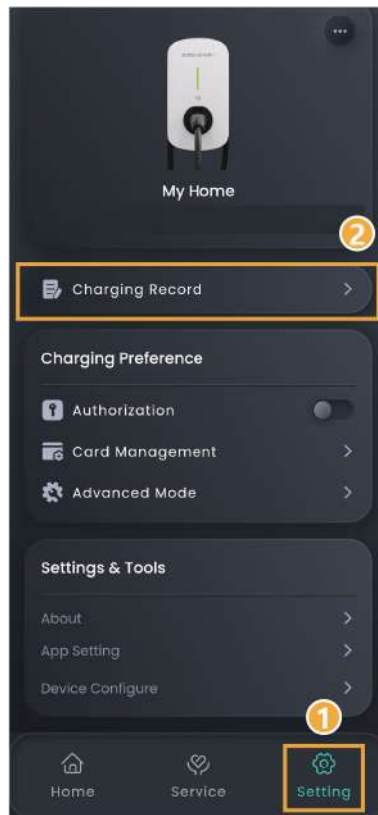

SSA1CM00069

PV charging or PV storage & charging application

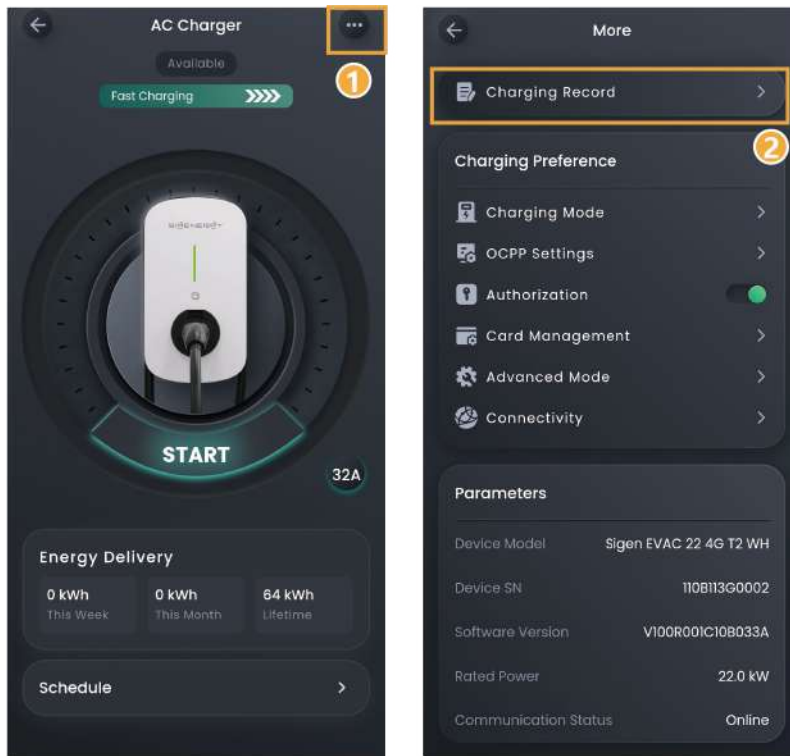

SSA1CM00069

Chapter 3 Service Page Information

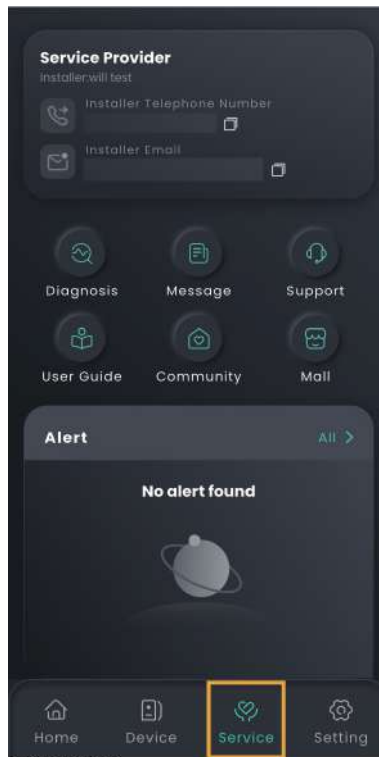

MSA1CM00070

No.	Parameter Name	Description
1	Service CRM	Click to query and process homeowner inquiry tickets.
2	Message	Click to view power station messages.
3	Support	<ul style="list-style-type: none"> Click to get regional contact information or submit tickets. Please feel free to reach out to us in the App if you have any questions about the use of the product. To check the tickets history, click "History" in the upper right corner of the "Support" page.
4	User Manual	Click to access the user Manual.
5	Community	Click to enter the forum interface. Click "Community" → "Guide Video" to view product installation videos.
6	Mall	Click to purchase products. Click  "View Order History" in the upper right corner.
7	Alert	Click "All" to view current and historical alarm information for all power stations.

Chapter 4 System Settings

4.1 Energy management settings

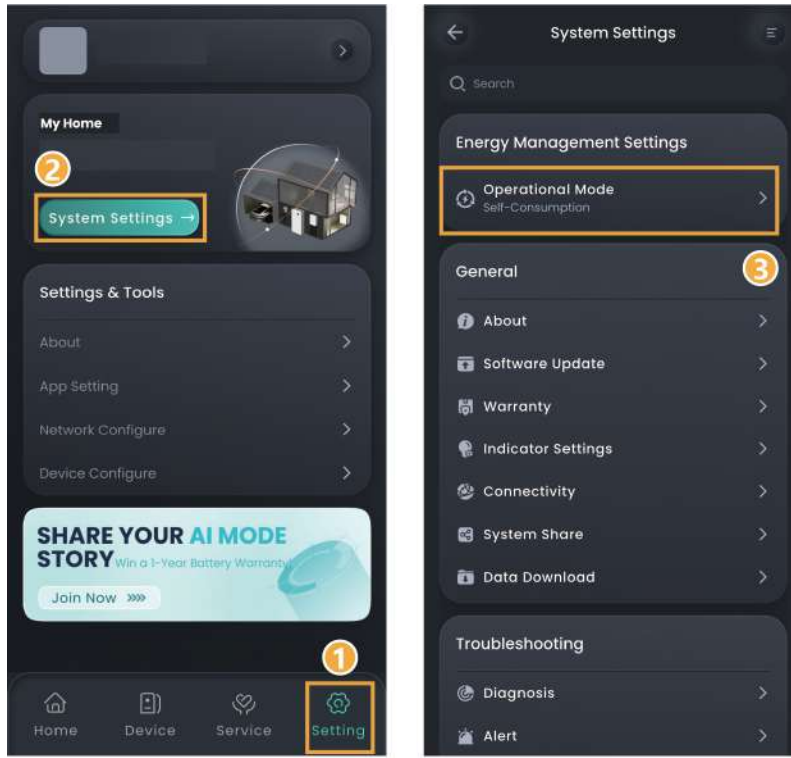

4.1.1 Operational mode

The energy storage system supports multiple operational modes, Some countries support Load Shedding Mode, VPP Scheduling-evergen Mode, which is subject to the App interface display.

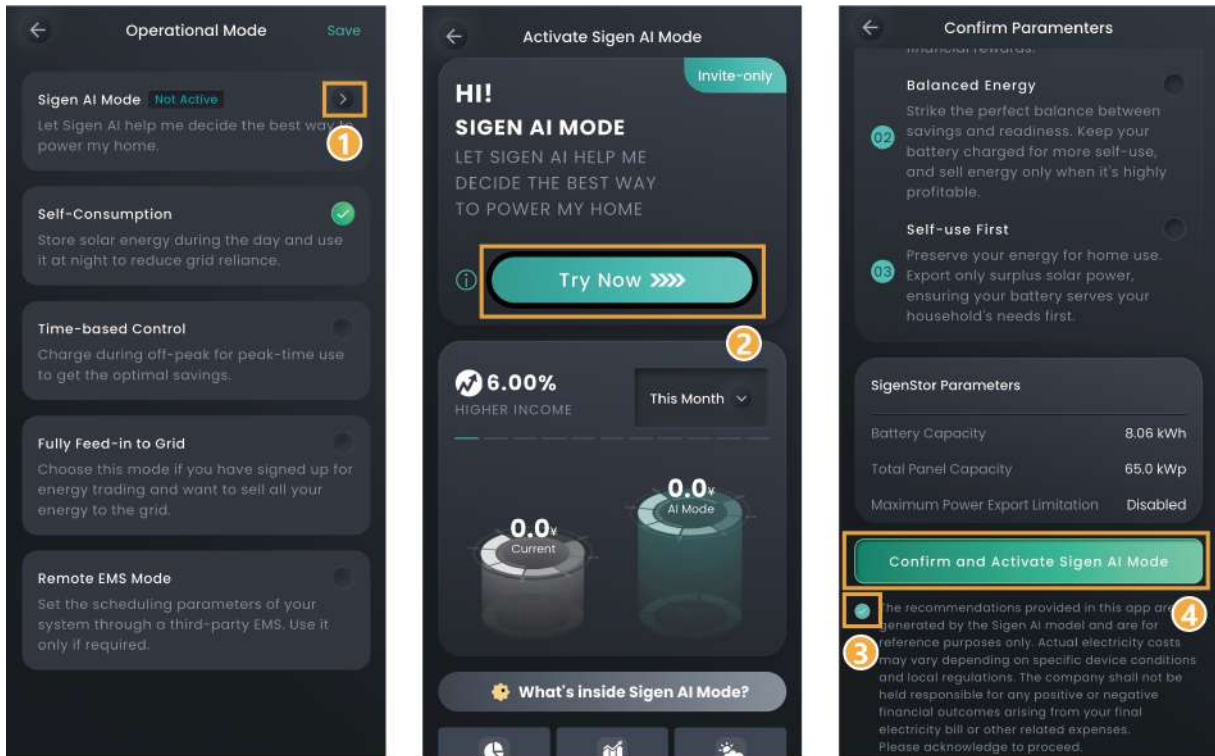

MSA1CM00074

Add Spike Load

Tips

- Peak load refers to the instantaneous surge in electricity demand.
- Adding peak load data can improve the accuracy of the "Production & Consumption Forecast" curve prediction.

Self-Consumption Mode (PLUS)

Tips

This parameter is available in some countries. Refer to the App interface for actual availability.

Function Description:

- When electricity prices are negative: Regardless of whether PV power is sufficient, the battery is prohibited from selling electricity to the grid. PV generation is prioritized for self-consumption or storage, reducing waste and increasing the proportion of self-consumed power.
 - When using an iMSys meter: The battery is prohibited from selling electricity to the grid.
 - When no iMSys meter is available: Smart limiting prevents power curtailment.
- When electricity prices are positive: AI predicts that negative prices will occur in the future, then the battery is forced to discharge to free up capacity for subsequent energy storage.

Operation Steps:

When Self-Consumption Mode is selected, click "Negative Price Protection" and set it to  to enable Self-Consumption Mode (PLUS).

Time-based Control Mode

- The charging period, discharging period, and self-consumption period need to be set manually. When electricity prices are high, the surplus power from photovoltaic power generation and battery power can be sold to the grid, and the battery can be charged during periods of low electricity prices to save electricity bills.
- If no period is set, the energy storage system will be in standby mode without discharging. The photovoltaic power will prioritize supplying the load, and the surplus power will be used for charging energy storage system.
- Up to 24 charging and discharging or self-consumption periods can be set.
- It is suitable for areas with peak and valley electricity prices and significant price differences.
- When entering this period, the battery capacity will be recorded. When the photovoltaic power is greater than the load, the remaining photovoltaic power will charge the battery. When the photovoltaic power is less than the load, the battery can be discharged to the load. However, when the battery capacity decreases and approaches the battery capacity value when entering this period, the battery will stop discharging.

— PV power generation curve
— Electricity consumption curve of household appliances

- The load draws power from the battery pack
- The load purchases electricity from the grid
- The load draws power from PV
- PV charges the battery pack
- PV generates electricity and sells it to the grid
- The load draws power from the grid and the battery pack

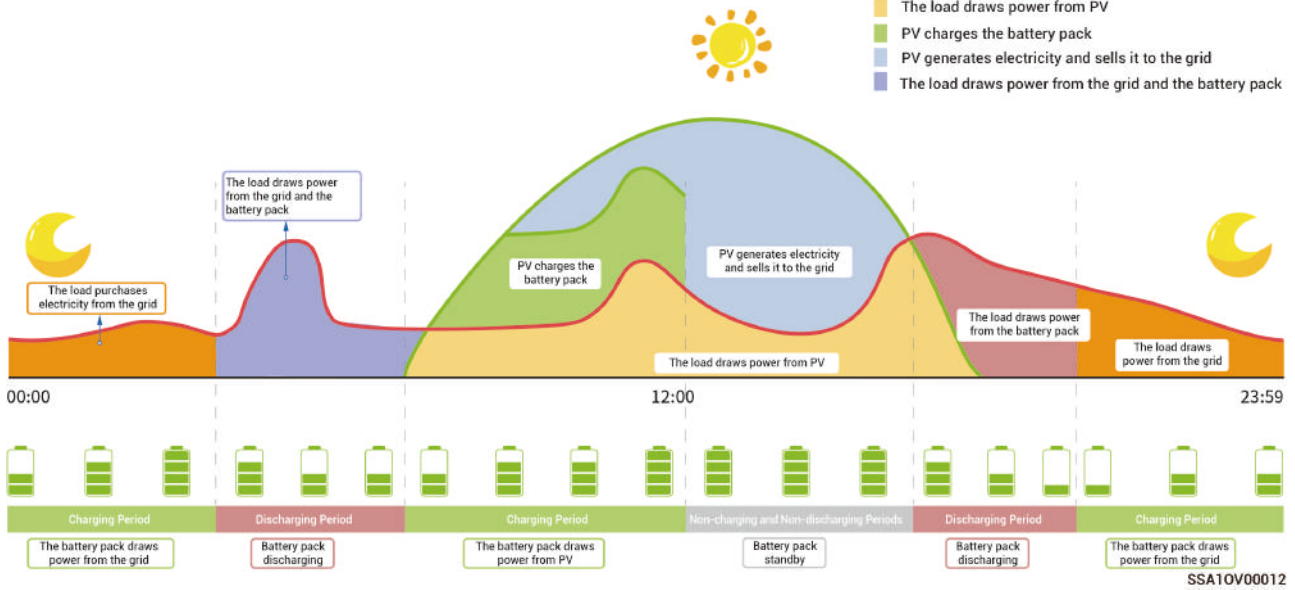

SSA10V00012

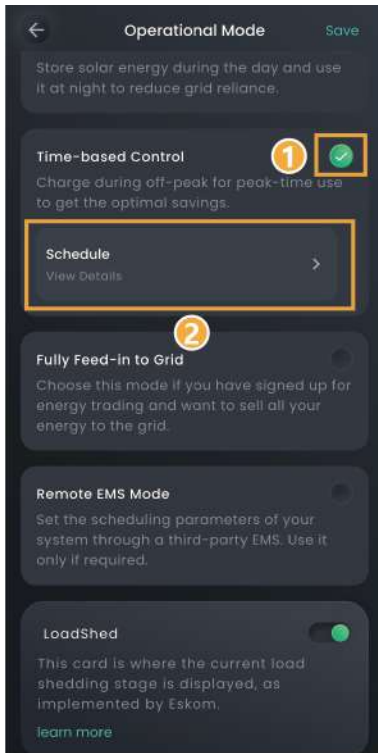

MSA1CM00074

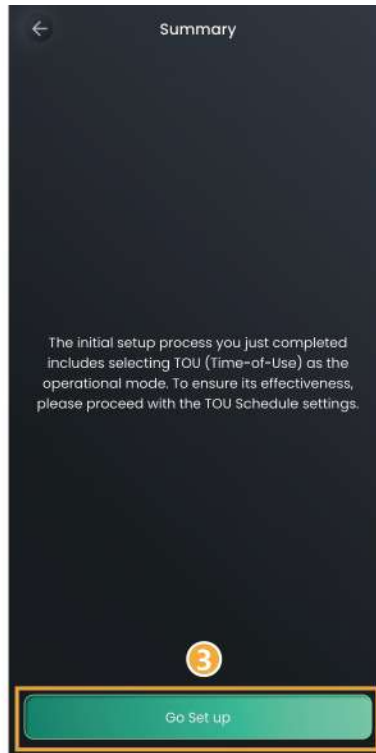

No.	Parameter name	Parameter name	Description
1	Charging	Maximum charging power for BAT	<ul style="list-style-type: none"> ● During this period, the sum of the charging power of all battery packs in the system cannot be greater than the "PACK maximum charging power." ● The system default value is set to infinity.

No.	Parameter name	Parameter name	Description
2	Charging	Grid Charging Cut-off SOC	<ul style="list-style-type: none"> ● Set the cut-off charging capacity value for the battery pack to be charged from the grid during this period. ● The system default is 100%.
3	Charging	Maximum power for importing from grid	<ul style="list-style-type: none"> ● The maximum power that can be imported from the grid during this period. ● System default values are effective according to the parameters in "System Settings → Energy Management Settings→Grid Settings".
4	Charging	Maximum Charging Power from Grid to BAT	<ul style="list-style-type: none"> ● The maximum power that the grid charges the battery pack during this period. ● The system default value is set to infinity.
5	Discharging	Maximum discharging power for BAT	<ul style="list-style-type: none"> ● During this period, the sum of the discharging power of all battery packs in the system cannot be greater than the "PACK maximum discharging power." ● The system default value is set to infinity.
6	Discharging	Maximum power for exporting to grid	<ul style="list-style-type: none"> ● The maximum power that the system is allowed to export to the grid during this period. ● System default values are effective according to the parameters in "System Settings → Energy Management Settings→Grid Settings".
7	Discharging	Maximum Discharging Power from BAT to Grid	<ul style="list-style-type: none"> ● The maximum power that the battery pack discharges to the grid during this period. ● The system default value is set to infinity.
8	Discharging	Discharge Cut-off SOC from BAT to Grid	<ul style="list-style-type: none"> ● Set the cut-off discharge capacity value for the battery pack to discharge power to the grid during this time period. ● The system default is 100%.
9	Self- Consumption	Maximum power for importing from grid	<ul style="list-style-type: none"> ● The maximum power that can be imported from the grid during this period. ● System default values are effective according to the parameters in "System Settings → Energy Management Settings→Grid Settings".
10	Self- Consumption	Maximum power for exporting to grid	<ul style="list-style-type: none"> ● The maximum power that the system is allowed to export to the grid during this period. ● System default values are effective according to the parameters in "System Settings → Energy Management Settings→Grid Settings".

The system will operate based on the PV power situation in periods that you do not specify as charging and discharging periods. The PV power will first be used to power home loads, with excess energy charging the batteries, and the batteries will not discharge.

Fully Feed-in to Grid Mode

- You can sell excess energy back to the grid and earn credits on your energy bill.
- In the daytime, when the PV power is greater than the maximum output capacity of the inverter, the inverter maintains the maximum output while storing excess energy in the batteries. When the PV power is lower than the maximum output capacity of the inverter or there is no PV power in the nighttime, the batteries are discharged to ensure that the inverter maximizes the output.

VPP Scheduling Mode

Once registered with the VPP, your storage system will join the smart dispatching network. The App will show and auto-enable this mode.

Remote EMS Mode

After setting to this mode, a third-party EMS dispatch company will be allowed to set the relevant parameters of the power station and products. Do not enter or exit this mode without the installer's confirmation.

Load Shedding Mode

In areas with frequent power outages, you can add your region and schedule in this mode, and the system will fully charge the battery in advance as scheduled, ensuring that you have battery power available to supply the load during outages. (currently only supported in South Africa)

Custom Operational Mode

Create Custom Operational Mode

Customized operation modes can be created according to owner requirements.

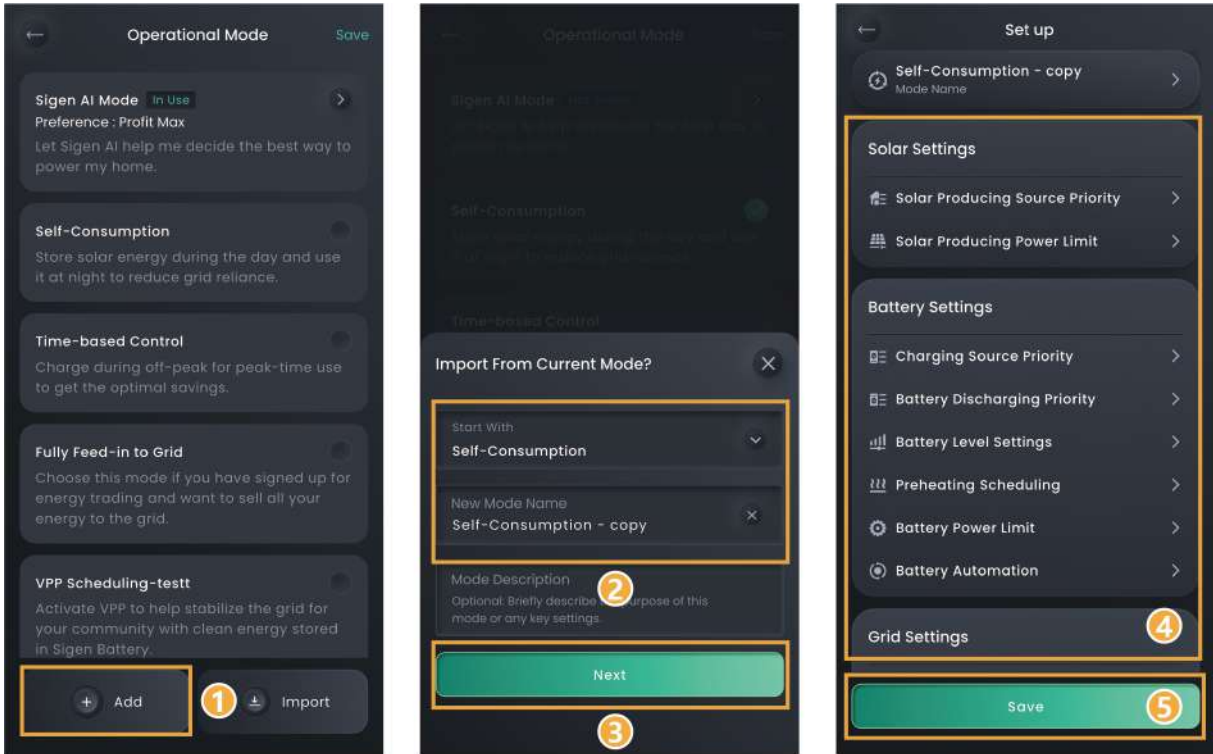

MSA1CM00074

Share Custom Operational Mode

Paste the sharing code to obtain others' custom Operational modes.

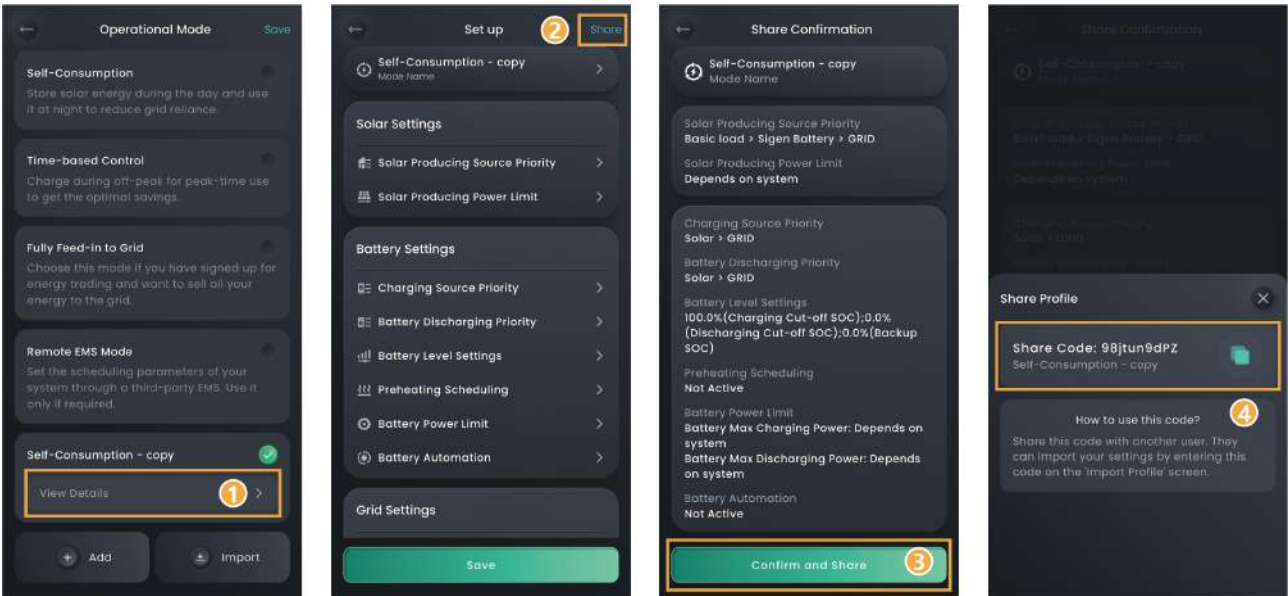

MSA1CM00074

Add Custom Operational Mode

Paste the sharing code to obtain others' custom Operational modes.

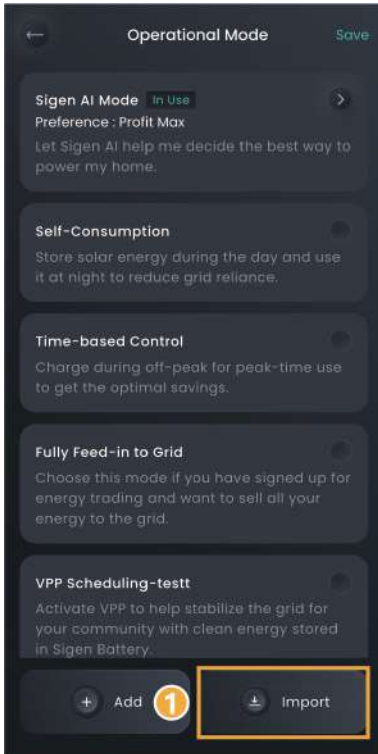

MSA1CM00074

4.1.2 Manual Control

When the battery capacity is too high or insufficient, the battery charging or discharging period can be forcibly set, and this parameter will be executed first after setting.

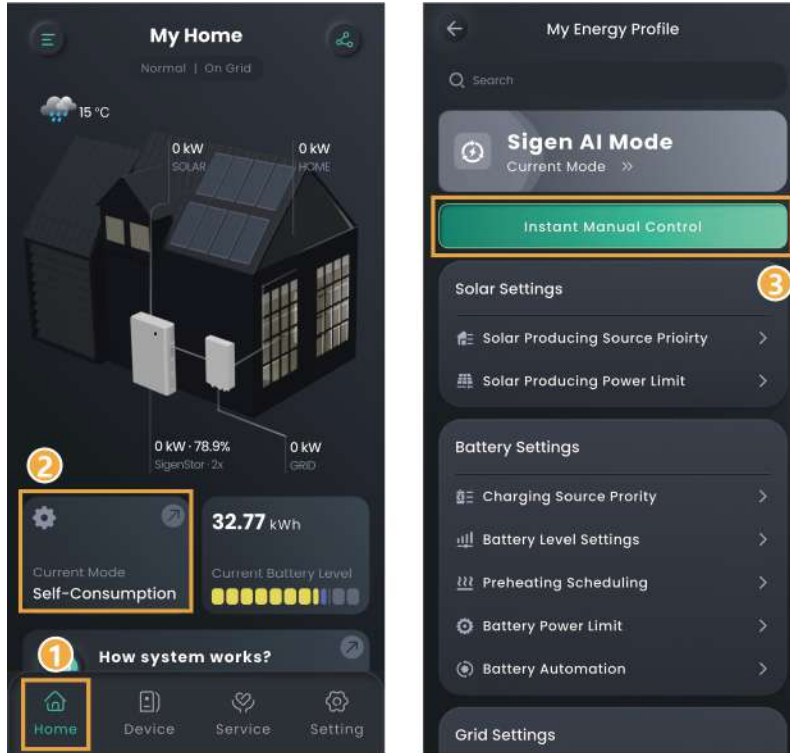

MSA1CM00068

No.	Parameter name	Description
1	Mode	<ul style="list-style-type: none"> ● Charging: Force the battery to be charged. ● Discharging: Force the battery to discharge. ● Hold Battery: The battery is neither charging nor discharging. ● Self-Consumption: The battery self - generates and self - consumes.
2	Period	Set the charging or discharging period.

4.1.3 Power station energy configuration

- The displayed parameters may vary for different power stations. Please refer to the actual interface.
- The displayed parameters may vary in different working modes. Please refer to the actual interface.
- Grayed-out parameters with  cannot be modified.

4.1.3.1 Solar Settings

Setting PV-related parameters can optimize power generation efficiency, ensure safe operation, and achieve intelligent energy management.

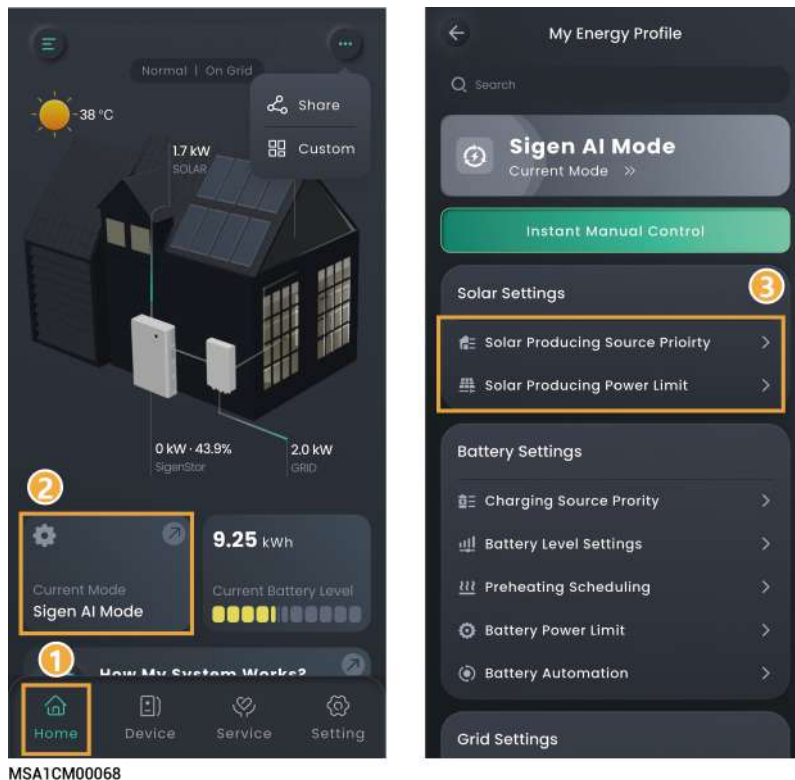

Solar Producing Priority

- The displayed parameters may vary in different working modes. Please refer to the actual interface.
- PV distributes the direction of the electrical energy according to the set order.

Solar Producing Power Limit

It is recommended to set this parameter in the negative electricity price scenario.

4.1.3.2 Battery Settings

Setting battery-related parameters can optimize battery performance, extend battery life, and achieve intelligent charging and discharging strategies.

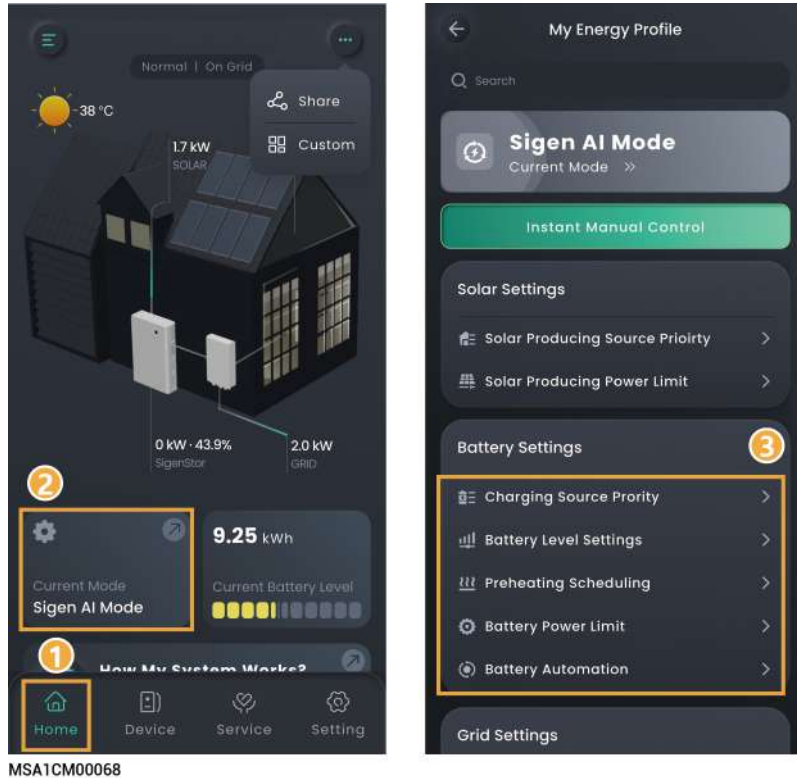

MSA1CM00068

Charging Source Priority

Tips

- The battery acquires power according to the set order.
- By default priority, PV is placed before Grid, PV solar charges the battery first, Grid supplements the remaining charge.
- In the negative electricity price scenario, Grid can be adjusted to be before PV.

Discharging Source Priority

Tips

Battery releases power according to the set order. The battery discharge priority can be configured based on the actual situation.

Battery Level Setting

No.	Parameter name	Description
1	Charge Cut-off SOC	Sets the capacity at which the battery pack stops charging.

No.	Parameter name	Description
2	Discharge Cut-off SOC	<p>Sets the capacity at which the battery pack stops discharging.</p> <ul style="list-style-type: none"> Value 0% is recommended for this parameter. The priority is given to "Backup Capacity" in backup system wiring mode, while the parameter is applied in non-backup system wiring mode.
3	Peak shaving	Set the battery peak shaving cutoff point.
4	Backup Reserve SOC	<ul style="list-style-type: none"> You can set this parameter when a gateway exists in the system wiring. In the on-grid scenario, the battery pack stops discharging when the backup capacity value is reached. In the off-grid scenario, the battery pack supplies power to power device and stops discharging when the Discharge Cut-off SOC setting is reached. Users can manually set this parameter according to the power interruption frequency of their regions and leave time. Value 0 is not recommended for this parameter to avoid irreversible attenuation due to failure to charge the battery pack in time.

Battery Preheating scheduling

Tips

Pre-adjust the battery temperature to the optimal working range in low temperature environments to prevent performance degradation and safety hazards caused by low temperature.



Household Energy Storage Power Station

No.	Parameter name	Description
1	Battery Preheating Scheduling	When it is set to  , the battery heating film preheating function is enabled.
2	Heating	Click to set the heating cycle of the battery heating film.

C&I Energy Storage Power Station

When Battery Preheating Scheduling is set to , you need to select the preheating mode.

Manual Setting

No.	Parameter name	Description
1	Smart Pre-heating	<p>When it is set to , the battery heating film preheating function is disabled.</p> <ul style="list-style-type: none"> Heating Duration: Used to set the heating duration of the battery heating film. <p>When it is set to , the battery heating film preheating function is enabled.</p> <ul style="list-style-type: none"> Target Working Period: Used to set the desired charging/discharging period for the heating film.
2	Heating	<p>Click to set the heating cycle of the battery heating film.</p> <p>Advanced Settings</p> <ul style="list-style-type: none"> Target Charging Power: The battery's charging power is limited due to low temperature. After heating is started, the heating film stops operating when the charging power is greater than this value. Target Discharging Power: The battery's discharging power is limited due to low temperature. After heating is started, the heating film stops operating when the discharging power is greater than this value.

Depends on System (Automatic)

Automatic mode is supported only when the power station is in TOU scheduling mode.

Battery Power Limit

Tips

If you need to set more detailed charging and discharging data, you can set this parameter.

No.	Parameter name	Description
1	Battery Max Charging Power	Set the maximum charging input power allowed by the battery.
2	Battery Max Discharging Power	Set the maximum discharging output power allowed by the battery.

Battery Automation

Tips

If this parameter is set, the battery will prioritize executing the parameters set by Battery Automation.

No.	Parameter name	Description
1	Add Time Period	Click to add Time Period.
2	Add your action	<p>Click to add battery operation status.</p> <p>Battery Charging</p> <ul style="list-style-type: none"> ● Maximum Charging Power: Set the maximum total input power allowed for the battery charging, including all charging sources. ● Maximum Charging Power From grid to BAT: Set the maximum charging input power from Grid to BAT. This parameter must be \leq Maximum Charging Power. ● Battery Charging From Grid Cut-off SOC: When the battery SOC reaches this threshold, the grid is forced to stop charging the battery. ● Battery Charging Source Priority: Adjust the battery energy source priority. <p>Battery Discharging</p> <ul style="list-style-type: none"> ● Maximum Discharging Power: Set the maximum total discharging output power allowed for the battery. ● Maximum Discharging Power from BAT to Grid: Set the maximum discharging output power from BAT to Grid. ● This parameter must be \leq Maximum Discharging Power. Discharge Cut-off SOC from BAT to Grid: When the battery SOC reaches this threshold, the BAT is forced to stop transmitting power to the grid. <p>Battery Preserve: Maintain the current SOC without change.</p> <p>Battery Self Consumption: The electrical energy of the battery is prioritized for supplying the load, and the remaining energy is sold to the power grid.</p> <ul style="list-style-type: none"> ● Maximum Charging Power: Set the maximum charging input power from PV to the battery. ● Maximum Discharging Power: Set the maximum discharging output power of the battery to the household load.

4.1.3.3 Grid Settings

Setting grid-related parameters can ensure safe grid connection, compliant electricity sales, and maximum revenue.

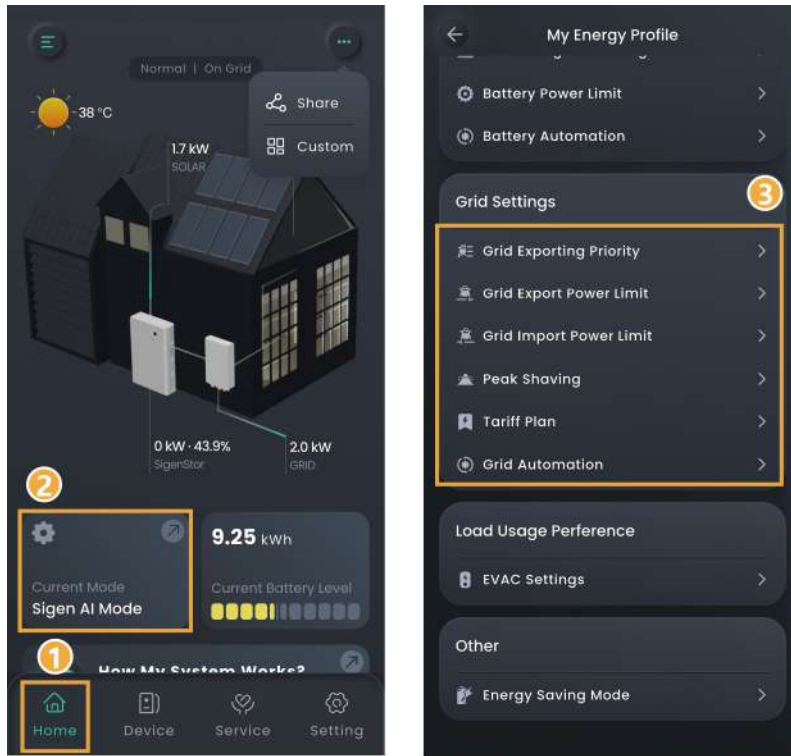

MSA1CM00068

Grid Exporting Priority

Tips

- By default priority, PV is placed before Battery. PV power prioritizes grid feed-in, with battery supplementing grid sales.
- In the negative electricity price scenario, Battery can be adjusted to be before PV.
- The device sells electricity to the grid according to the set order.

Grid power setting

No.	Parameter name	Description
1	Grid Export Power Limit	Set the system's maximum power for selling electricity to the grid.
2	Grid Import Power Limit	Set the system's maximum power for buying electricity from the grid.

Peak Shaving

Tips

- The electricity bill in some regions is calculated as follows: Total electricity bill = Cost at peak power + cost for electricity usage + other costs. Wherein, peak power refers to the maximum power imported from the grid. This mode is suitable for areas with peak and valley electricity prices and significant price differences.

Tips

- The Peak Shaving function can be used with all working modes, configuring the maximum peak power drawn from the grid to reduce the maximum peak power drawn from the grid during peak periods, thereby lowering the electricity bill.

Active Power Control

No.	Parameter name	Description
1	Peak shaving SOC	This parameter setting affects the capacity of peak shaving, and the system charges the battery to the set SOC value during the off-peak period. The larger the parameter setting, the stronger the peak shaving capability.
2	Schedule	A maximum of 24 timetables can be added.
3	Maximum Peak Power	Set the maximum peak power for drawing electricity from the grid for household loads and battery packcharging.

Example 1: Self-Consumption Mode Settings for Peak Shaving

Assume that the peak shaving SOC is set to 50% and the maximum peak power is 2kW. Because Total electricity bill = Cost at peak power + cost for electricity usage + other costs. Wherein, peak power refers to the maximum power imported from the grid. After Self-Consumption Mode is set to Peak Shaving, the power purchased from the grid drops from 5 kW to 2 kW, so the total electricity bill is reduced.

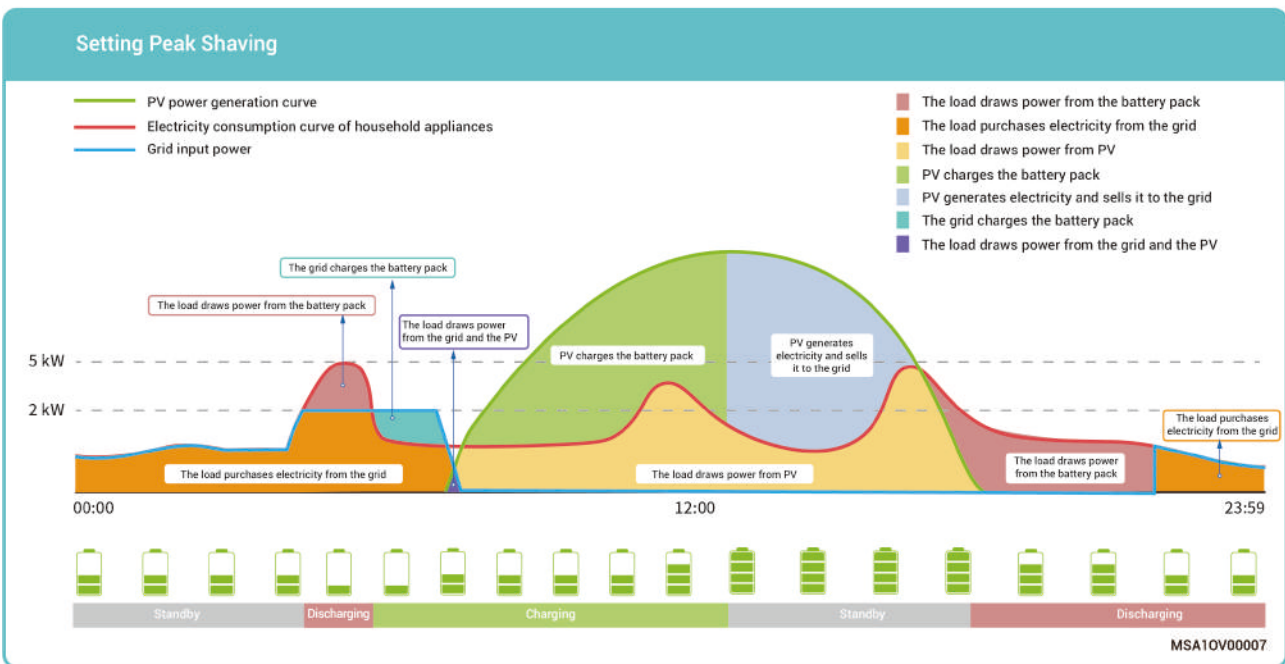
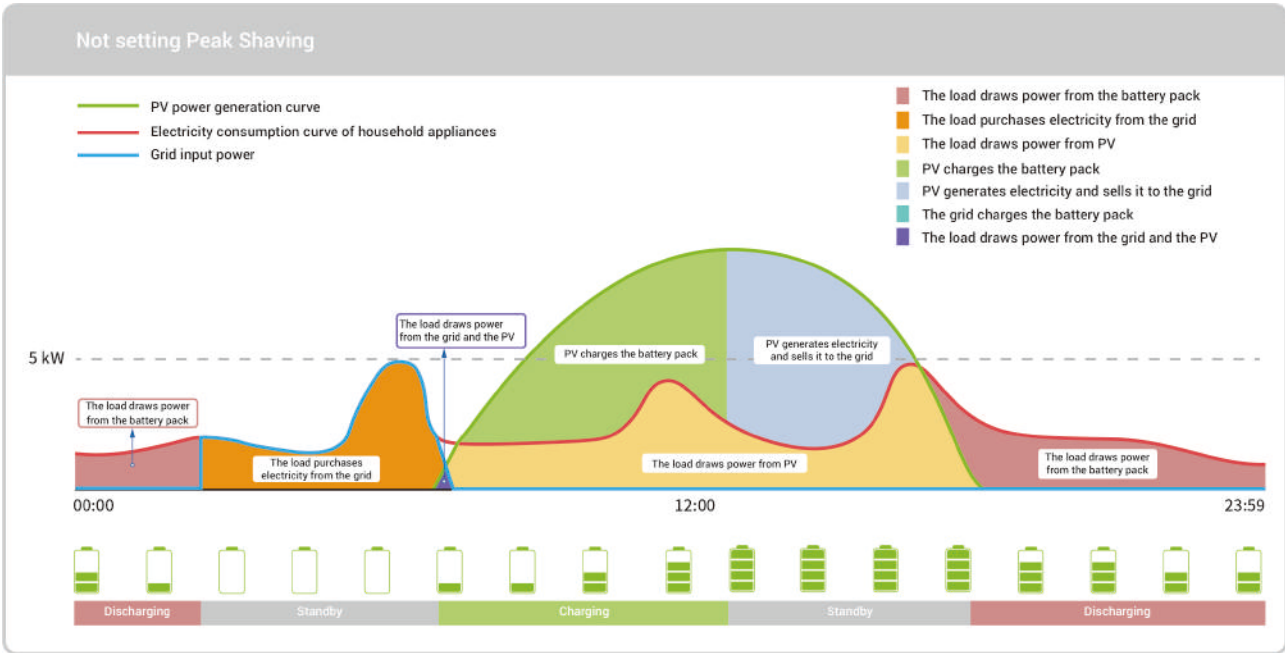

Example 2: Time-based Control Mode Settings for Peak Shaving

Assume that the peak shaving SOC is set to 50% and the maximum peak power is 2kW. Because Total electricity bill = Cost at peak power + cost for electricity usage + other costs. Wherein, peak power refers to the maximum power imported from the grid. After Time-based Control Mode is set to Peak Shaving, the power purchased from the grid drops from 5 kW to 2 kW, so the total electricity bill is reduced.

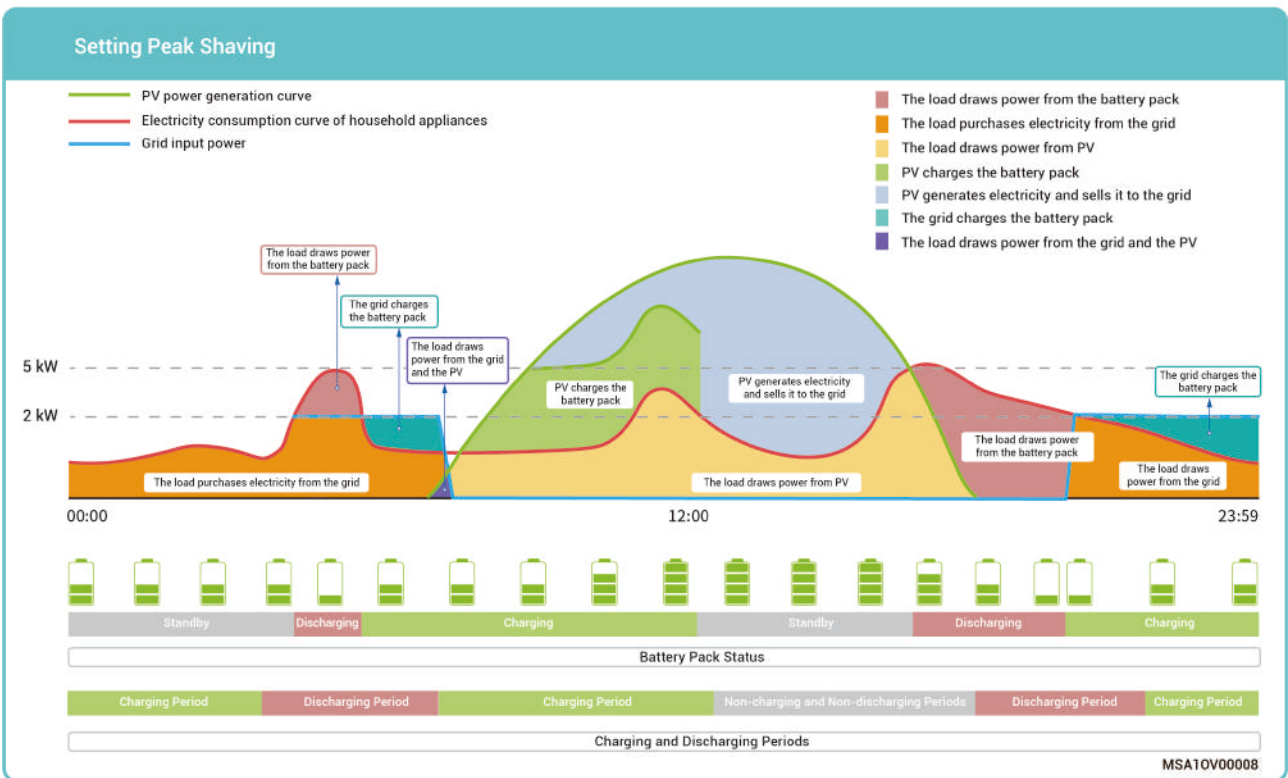
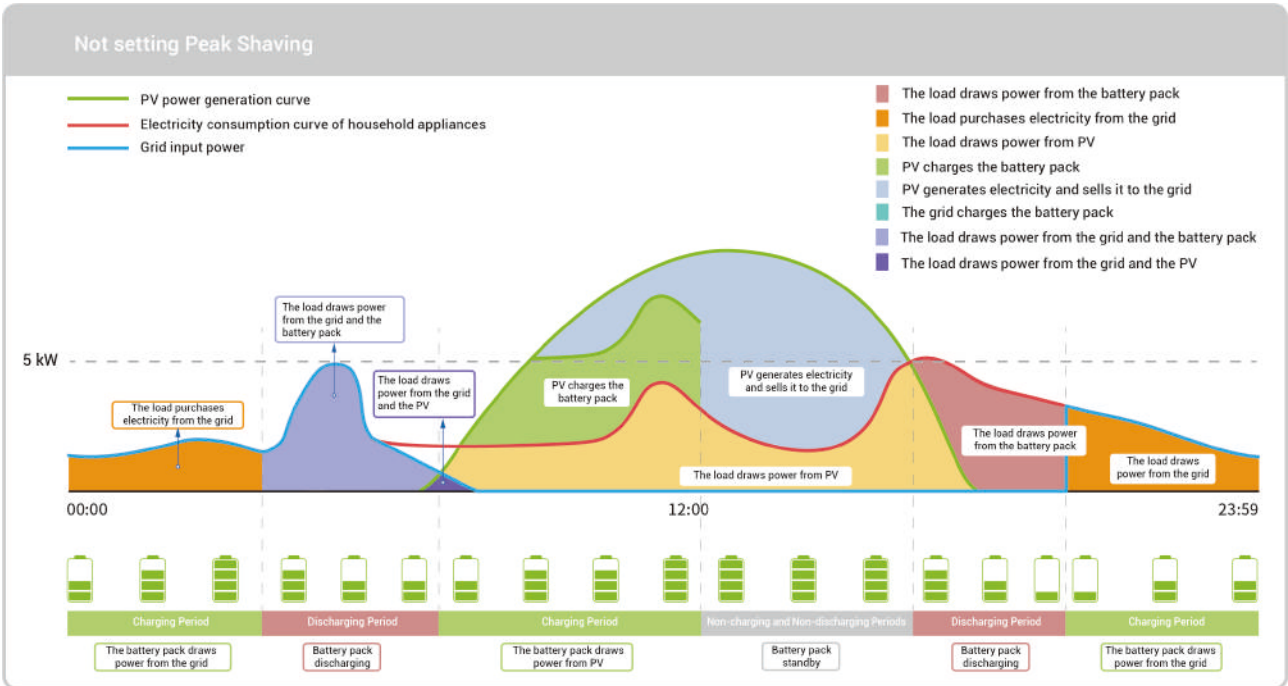

Tariff Plan

Tips

- To create a new tariff plan: Click "Tariff Plan" → "Add My Rate" to create and configure your electricity price plan.

Tips

- To import a saved plan: If you have previously saved a tariff plan, click "Tariff Plan" → "Import Saved Tariff" to load it directly.

Tariff Rate Plan

- Dynamic tariff refers to a pricing model where the electricity tariff changes in real time according to time and different regions.
- Some electricity rate operators require entering a Secret Key. Please refer to the actual display in the App interface.

No.	Parameter name	Description
1	Utility Company	Select an electricity price operator and automatically match the corresponding electricity price (wholesale price/retail price).
2	(Optional) Secret Key	Used to set a secret key of the utility company. After the key is set, the app can get and display the electricity tariff.
3	Rate Plan Name	Select an electricity tariff plan.
4	Currency Unit	The value is defaulted to the smallest currency unit of the electricity tariff in the country/region where the power station is located. This parameter cannot be edited.
		<p>Click "Go To Setting" to configure the tax rate and additional fees.</p> <p>Tax Type</p> <ul style="list-style-type: none"> ● Fixed Tax Rate <ul style="list-style-type: none"> <input type="checkbox"/> The same tax rate applies to all time periods. <input type="checkbox"/> Total Electricity Cost = (1.0 + Fixed Tax Rate) × (Electricity Price + Additional Fee Z) + Additional Fee N. ● Time-of-Use Rate <ul style="list-style-type: none"> <input type="checkbox"/> Different tax rates apply to different time periods. Click  to add time periods and set corresponding tax rates for buying/selling electricity. <input type="checkbox"/> Total Electricity Cost = (1.0 + Time-of-Use Tax Rate) × (Electricity Price + Additional Fee Z) + Additional Fee N. <p>Separate Tax for Negative Prices: This parameter defaults to "NO". If negative electricity prices are taxed separately, select "YES" and set the tax rate for negative prices.</p>

No.	Parameter name	Description
5	Additional Fee	<p>Click "Add" to include additional fees, or click "Skip" to proceed without adding any.</p> <p>Additional Fee Name: Enter the name of the additional fee.</p> <p>Additional Fee Type</p> <ul style="list-style-type: none"> ● Fixed Additional Fee: The same additional fee applies to all time periods. ● Time-of-Use Rate: Different additional fees apply to different time periods. Click , to add time periods and set corresponding additional fees for buying/selling electricity. <p>Apply Tax If set to "YES", the additional fee will be placed under Additional Fee Z; if set to "NO", it will be placed under Additional Fee N.</p>
6	Demand Charge	Click "Go To Settings" to set the demand charge.
7	Customize	Click to switch to Customize Rate Plan.

Customize Rate Plan

Static tariff refers to a pricing model in which the electricity tariff remains fixed and is not adjusted based on time, supply and demand conditions, or system cost fluctuations, throughout the entire billing cycle.

No.	Parameter name	Description
1	Utility Company	Select a utility company.
2	Rate Plan Name	Enter the name of the electricity rate plan.
3	Currency Unit	The value is defaulted to the smallest currency unit of the electricity tariff in the country/region where the power station is located. This parameter cannot be edited.
4	Rate Plan Type	<p>Single Rate Tariff: A single electricity tariff applies to all time periods. Rate Tariff: Used to set the electricity tariff rate.</p> <p>TOU Rate Plan: Different electricity tariffs are applied in different time periods.</p> <p>Click , to add custom time periods, electricity tariffs, and other information.</p>
5	Go to settings to enable it	Click to switch to Tariff Rate Plan.

Demand Charge Settings

Demand charge refers to a two-part tariff model in which charges are not only made based on electricity consumption but also made according to the user's highest power demand within a billing cycle.

No.	Parameter name	Description
1	Currency Unit	The value is defaulted to the smallest currency unit of the electricity tariff in the country/region where the power station is located. This parameter cannot be edited.
2	Demand Interval	Used to set a billing settlement cycle.
3	Reset Frequency	Used to set a power calculation cycle.
4	Rate Plan Type	<p>Single Rate Tariff: The same demand charge applies to all time periods.</p> <p>Demand Rate Tariff: Used to set the demand charge rate.</p> <p>TOU Rate Plan: Different demand charges are applied in different time periods.</p> <p>Click  to add custom time periods, electricity tariffs, and other information.</p>

Save electricity price configuration

Tips

- After creating a new tariff plan, click "Save To Account" to save it to the installer's personal account.
- To view saved tariff configurations, click "Settings" → your account avatar → "My Saved Tariff Plan".

Grid Automation

Tips

If this parameter is set, the grid will prioritize executing the parameters set by Grid Automation.

No.	Parameter name	Description
1	Add Time Period	Click to add Time Period.

No.	Parameter name	Description
2	Add your action	<p>Click to add grid operation status.</p> <ol style="list-style-type: none"> 1. Grid Self-Consumption: The battery's power is supplied to the load first, and the surplus electric energy is sold to the grid. 2. Grid Importing: Set the maximum total input power for selling electricity to the grid, including all power sources within the system. 3. Grid Exporting: Set the maximum total output power for buying electricity from the grid, including all power sources within the system. <ul style="list-style-type: none"> ● Maximum power for importing from grid: Set the maximum input power for importing from the grid. Maximum power for exporting to grid: Set the maximum output power for exporting to the grid. ● Maximum power for importing from grid: Set the maximum input power for selling electricity to the grid. ● Maximum power for exporting to grid: Set the maximum output power for buying electricity from the grid. Grid Exporting Source Priority: The device sells electricity to the grid according to the set order.

4.1.3.4 Backup Setting



Backup Reserve

Tips

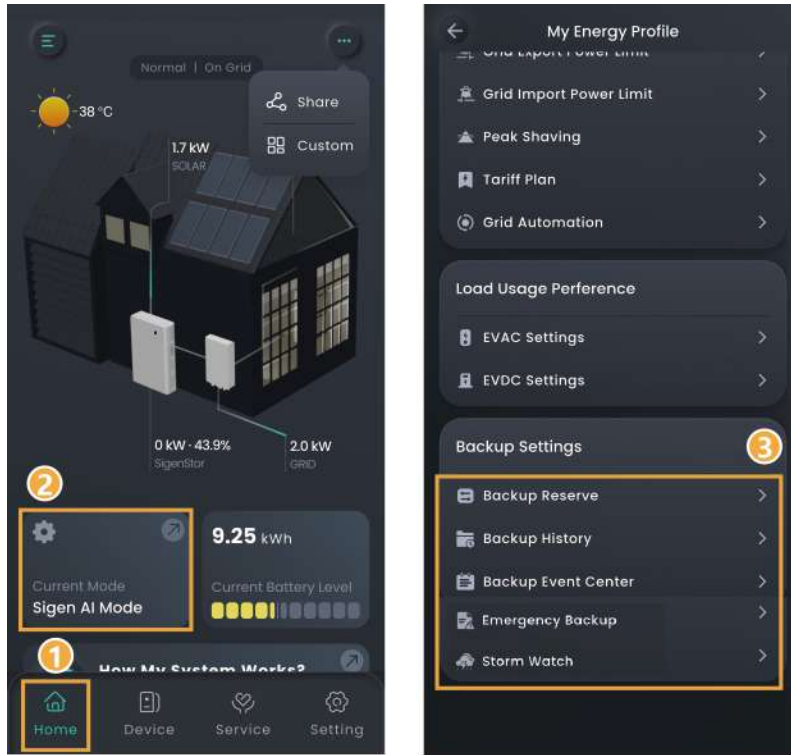
- This feature is only available for power stations equipped with a battery and a Gateway, and with off-grid capability enabled.
- Users can manually set this parameter according to the power interruption frequency of their regions and leave time.
- The parameters displayed may vary for different regions and power stations. Please refer to the actual interface shown in the App for specific details.



MSA1CM00086

No.	Parameter name	Description
1	Backup Reserve	In grid connection mode, the battery stops discharging when the backup power SOC setting is reached. In the event of grid power outage, the backup power becomes available.
2	Backup History	After Gateway is installed in the system, the system records on-grid/off-grid events. You can view the time and reason for the on-/off-grid switch-over through the following methods.
3	Backup Event Center	Click to view backup power events.
4	Emergency Backup	When set to  , the emergency backup function is enabled. Once activated, as long as the device's power supply is normal, the system will immediately charge the battery to full capacity to ensure backup power is available in case of an emergency.
5	Storm Watch	When set to  , the Storm Watch function is enabled. Once activated, as long as the device's power supply is normal, the system will automatically charge the battery to full capacity in advance upon detecting extreme weather warnings, in order to mitigate the risk of potential power interruptions.

If there is a gateway in your networking, you can manually set the "Backup Reserve" value in the mySigen App. In grid connection mode, the battery stops discharging when the backup power SOC setting is reached. In the event of grid power outage, the backup power becomes available. For example, the backup power SOC is set in Self-Consumption Mode.

— PV power generation curve
 — Electricity consumption curve of household appliances

- The load draws power from the battery pack
- The load purchases electricity from the grid
- The load draws power from PV
- PV charges the battery pack
- PV generates electricity and sells it to the grid

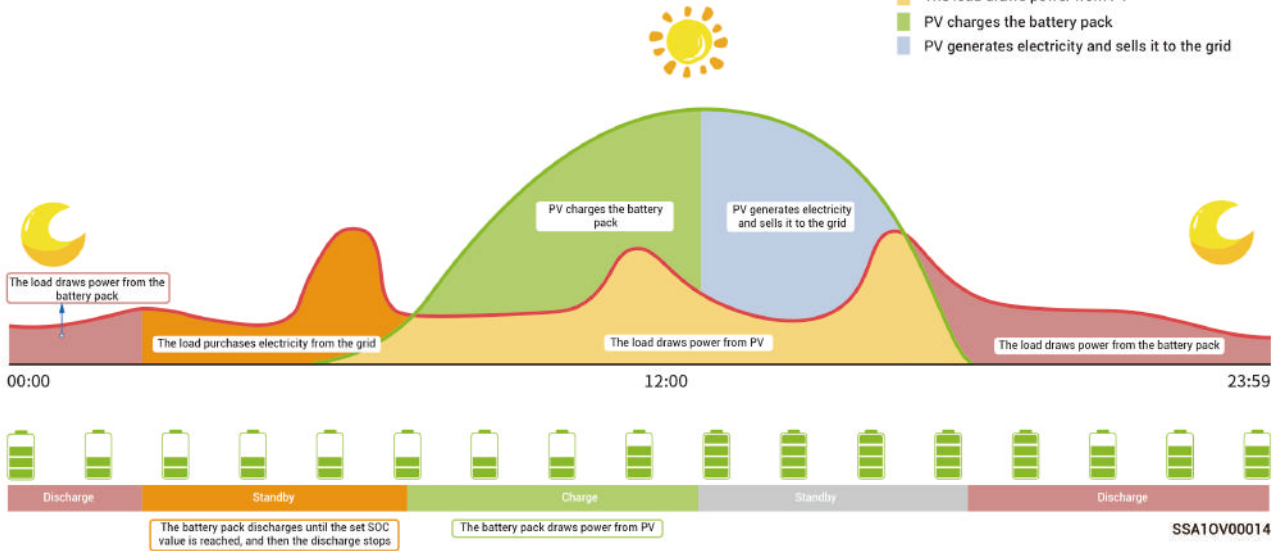

4.2 Energy Saving Mode

Tips

After configuration, the power consumption of the device can be reduced. You can select the Performance Mode or Deep Energy-Saving Mode according to actual needs.

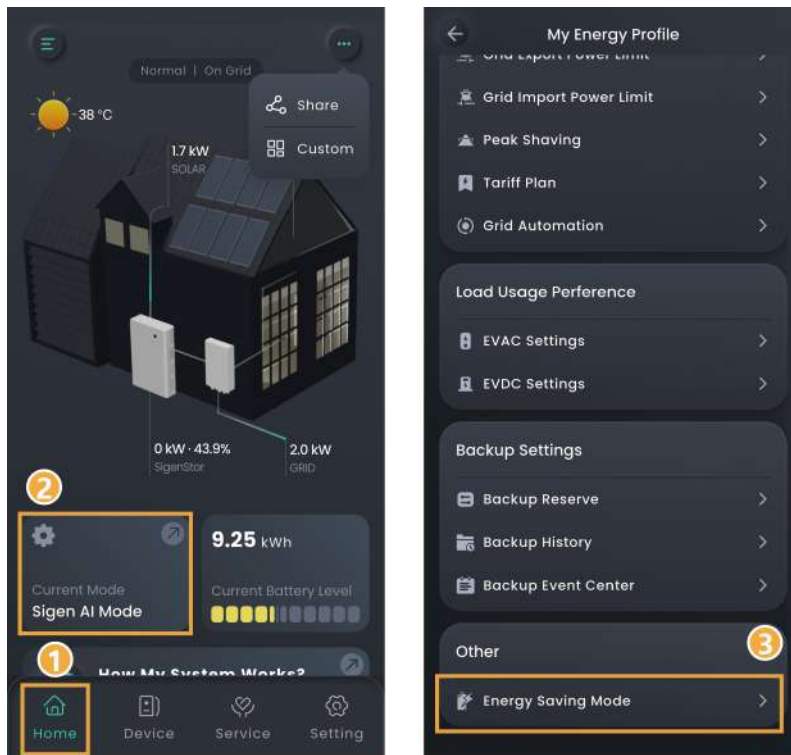

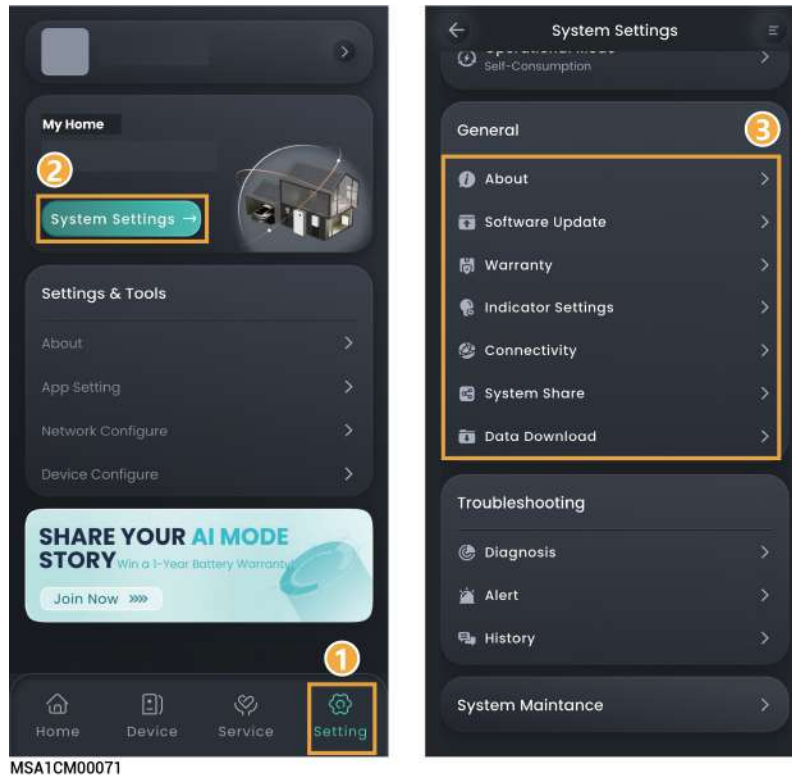

MSA1CM00068

4.3 General setting



MSA1CM00071

No.	Parameter Name	Description
1	About	Click to modify the power station type, name, and address.
2	Software upgrade	Click to upgrade the power station software. You can use this function to check whether the system software is updated to the latest version and upgrade the device to the latest version when necessary. Clicking this button will upgrade all Sigenergy devices in the power station, including but not limited to SigenStor, Sigen EV AC Charger, Gateway, etc.
3	Warranty	Click to view the warranty status.
4	Indicator Settings	Click to set the LED indicator effects. When set to  , You can set the LED lighting effect according to your preference. When "LED Strips" is set to "Power Flow," the flowing water lighting effect from the top down indicates that the battery pack and charger are charging and the flowing water lighting effect from the bottom up indicates that the battery pack and charger are discharging. The steady-on lighting effect indicates that the battery pack and charger are not charging or discharging.
5	Connectivity	View the network connection type and topology diagram.
6	System Share	Click to share power station information.
7	Data Download	Click to download power station information.

No.	Parameter Name	Description
8	Modbus TCP Server	When set to  , You can view the IP address.
9	(Optional) DER Aggregator Service	<ul style="list-style-type: none"> This parameter is only available in select countries (e.g., the United States). Actual availability is subject to the interface. After clicking, you will complete the signing or registration process with a third-party virtual power plant (VPP) operator. Your energy storage system will be connected to the VPP smart dispatch network, and the VPP Schedule mode will be automatically selected in the App's energy storage working mode interface.
10	(Optional) SGIP Report	<ul style="list-style-type: none"> This parameter is only available in the United States. Click to export power station parameters from the past 7 days for applying for government subsidies.

Power Station Remote Network Connection

Tips

- It is recommended to use Fast Ethernet and WLAN for communication with inverters. When free 4G traffic of CommMod runs out, users must top up their accounts or replace a SIM card.
- Certain features are only supported on SigenMicro power stations and require the latest software version. Please refer to the actual interface display for availability.

No.	Parameter name	Description
1	Ethernet	Displays the connection status of Fast Ethernet. Do not disconnect the network cable when the Internet connection is stable.
2	WLAN	<p>Displays the connection status of WLAN. Here you can configure the WLAN for all devices in the power station.</p> <p>Before configuring the WLAN, please make sure that antennas are installed on devices. Non-encrypted WLAN is not recommended as it may lead to Internet access failure. When WLAN is the only connection path for the devices to access the internet, switching WLAN to any other wireless router will be prohibited.</p> <p>Add WLAN Click "Add a network" to add a WLAN.</p> <p>Switch WLAN</p> <ul style="list-style-type: none"> When the power station has two or more WLAN configurations, customers can manually select the WLAN configuration for the corresponding device. Click "My WLAN" or "Other Network" to switch the WLAN. <p>Delete WLAN</p> <ul style="list-style-type: none"> When the power station has two or more WLAN configurations, customers can delete WLANs not in use by the system. Under My WLAN, swipe left and click  to delete a WLAN.

No.	Parameter name	Description
3	Cellular	<ul style="list-style-type: none"> ● Displays whether the 4G network is connected to the Internet. ● When 4G is used for communication users can view the monthly traffic usage and set a traffic usage threshold for each month. <p>(Optional) Cellular Settings:</p> <ul style="list-style-type: none"> ● If you are using a non-Sigenergy SIM card, you can configure these parameters. ● Tap to set the operator, APN name, username, password, and authentication method. Once completed, the device can connect to the 4G network. <p>(Optional) SMS Control:</p> <ul style="list-style-type: none"> ● These parameters are available in certain regions, depending on the App interface. ● If you are using a non-Sigenergy SIM card and the 4G connection status is "Connected", you can configure these parameters. ● Tap to set the authorized mobile number and SMSC. Once completed, if the device is offline or experiences a network anomaly, the authorized mobile number can remotely control the power station device to power on/off or reboot by sending SMS commands.

4.4 Troubleshooting

The parameters that can be configured vary depending on the country or power plant. Please refer to the actual interface for details.

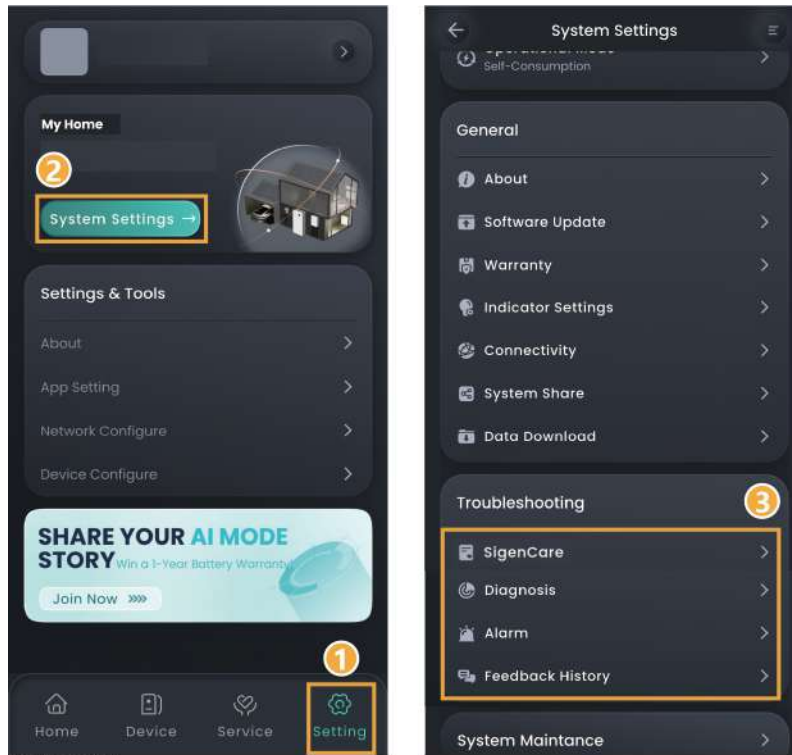

MSA1CM00071

No.	Parameter name	Description
1	(Optional) Sigen-Care	Click to perform a comprehensive analysis of six core dimensions of the power station, including environmental reliability, revenue performance, device reliability, network reliability, energy storage health, and system capacity configuration. Generate intuitive health scores and diagnostic reports to help users quickly understand the operating status of the power station, promptly identify potential issues, and ensure asset security and maximized revenue.
2	Diagnosis	You can use this feature to check the communication status of the station and connection status of devices in the station.
3	Alert	Click to view the alarm information of a single power station. When the system is operating off-grid, and the inverter shuts down due to a communication failure of the Gateway, and if the Gateway cannot automatically clear the alert upon power-on after communication is restored, you can click "Alert" → "Clear" to restart the inverter, and the Gateway will resume power supply, and the alert can be cleared.
4	Feedback History	Click to view historical work orders.
5	(Optional) Operation Log	Click to download the operation log of the power station.

4.5 System Maintenance

System Power-on/Power-off

Tips

This function is not supported in the Japan region.

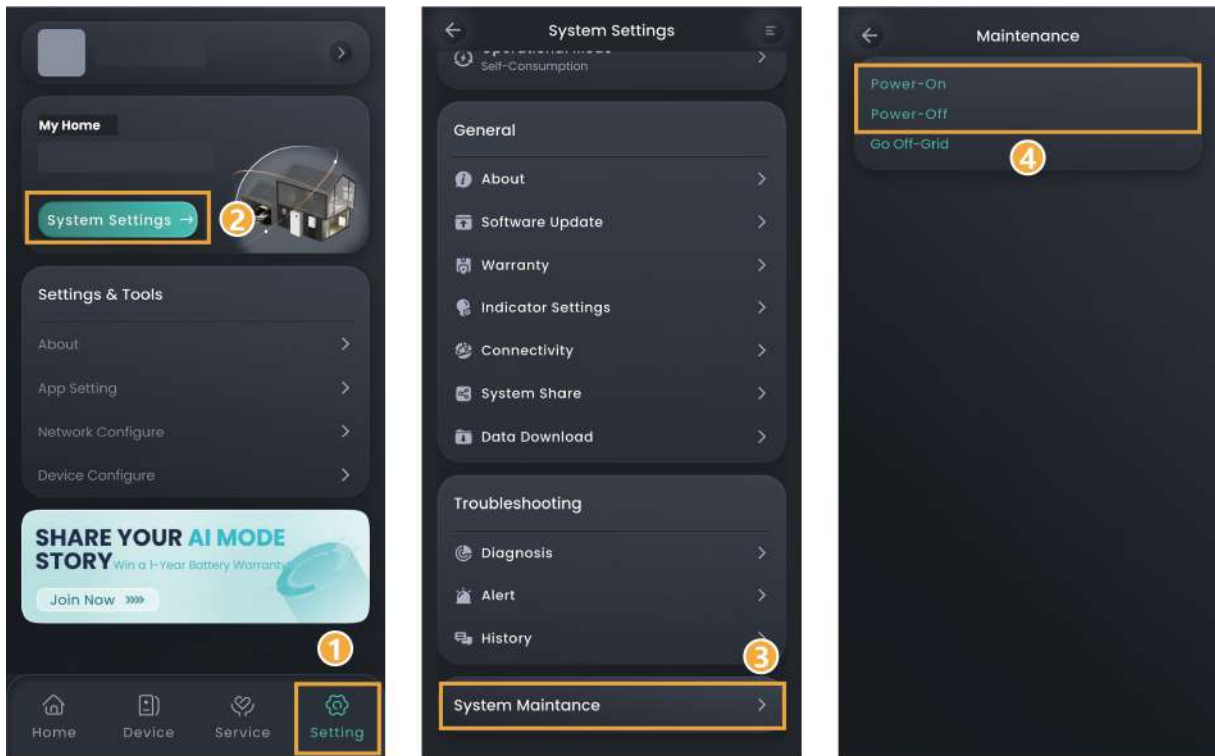

MSA1CM00071

On-grid/Off-grid switchover

Tips

Skip this section if no Gateway is configured.

Danger

- When set to "Go-Off-Grid," your inverter supports off-grid operation. During off-grid operation, the anti-islanding function of the inverter will be turned off.
- Before you perform any operation of the power distribution system (such as installation, wiring, or replacement), ensure that all power supplies and their corresponding circuit breakers are disconnected. This includes the power switches of the power grid side, inverter and diesel Generator to avoid operation with power on.

Method 1:

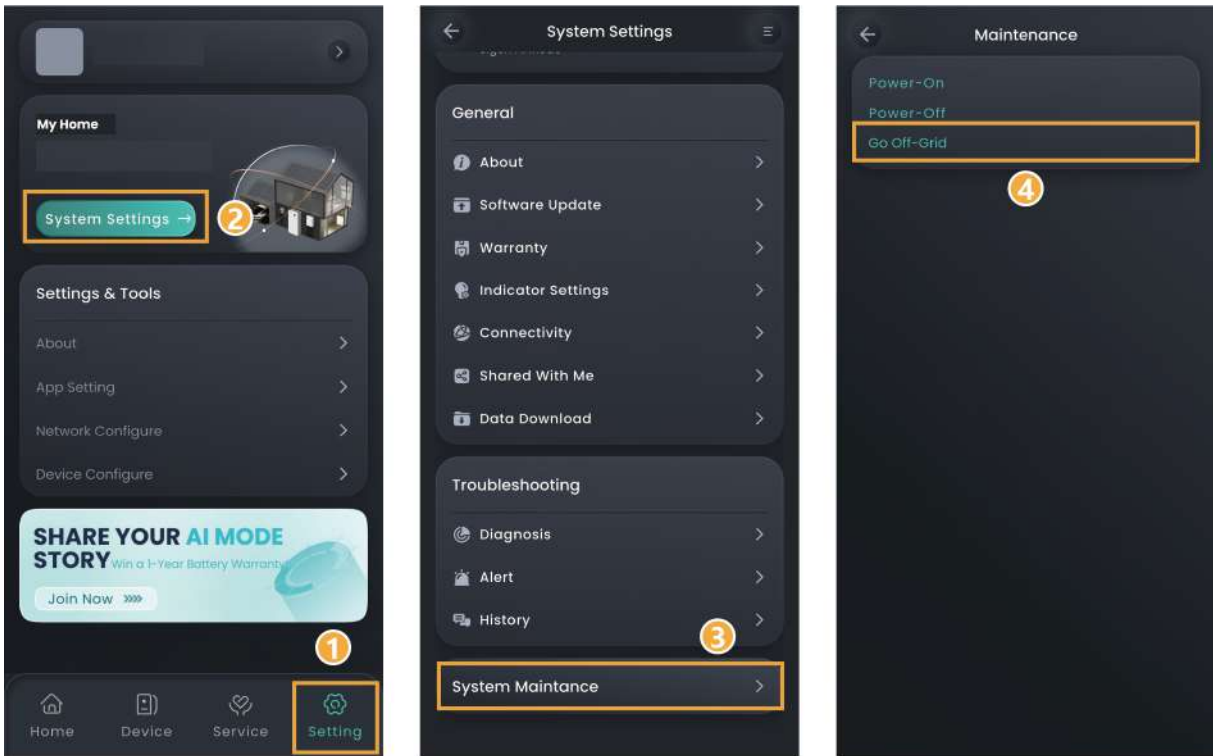

MSA1CM00071

Method 2:

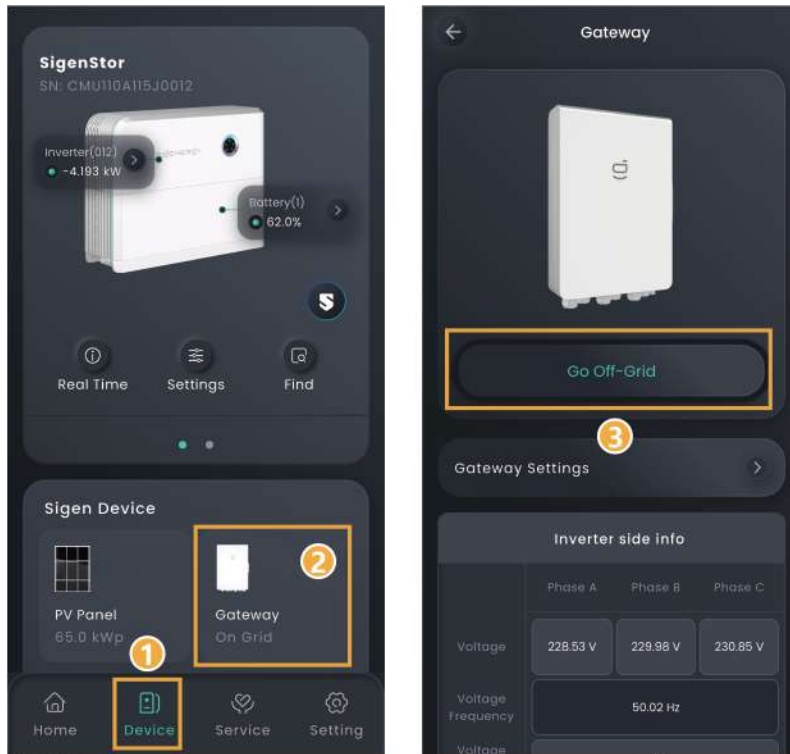

MSA1CM00069

Chapter 5 Main Device parameter setup

5.1 SigenStor/SigenStack Unit Settings

History maintenance

- When you click "Reset," the device restarts.
- When you click "Erase All Content," performance data within 5 minutes, alarms, and hourly/daily/monthly/yearly generating capacity, operation logs, device information will be cleared. Please exercise caution with this action.

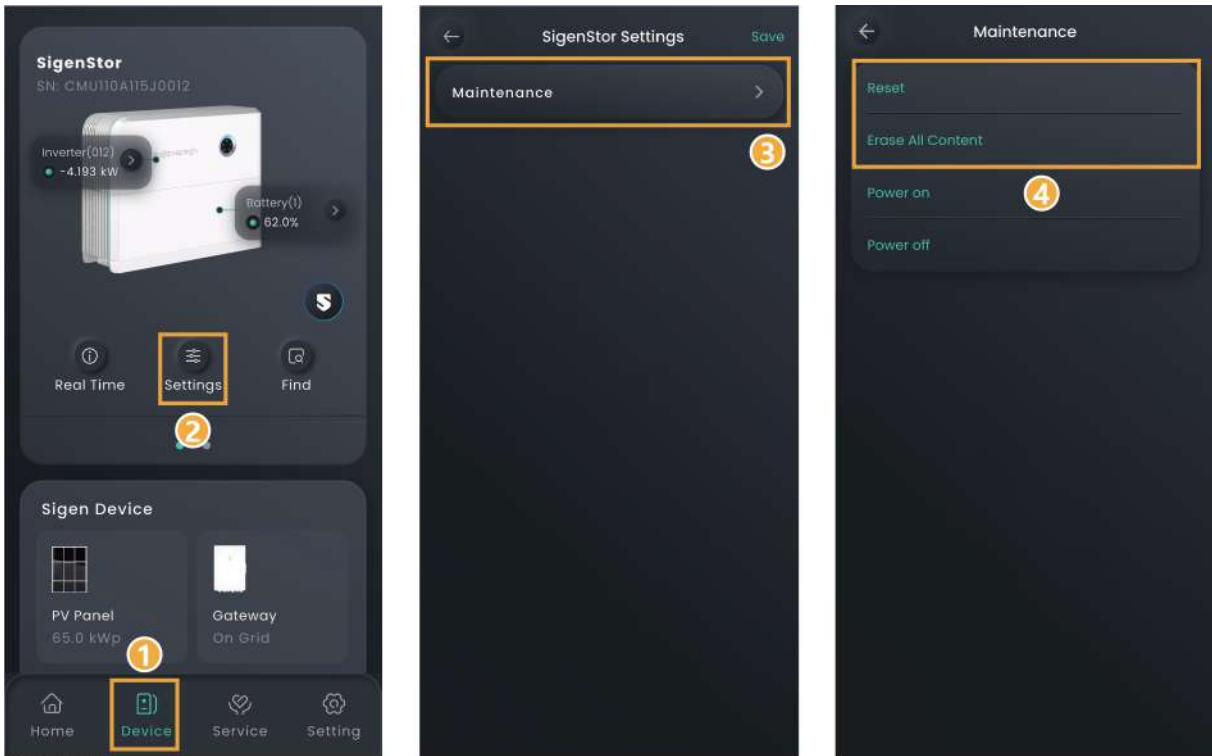

Power on/off

This function is not supported in the Japan region.



MSA1CM00069

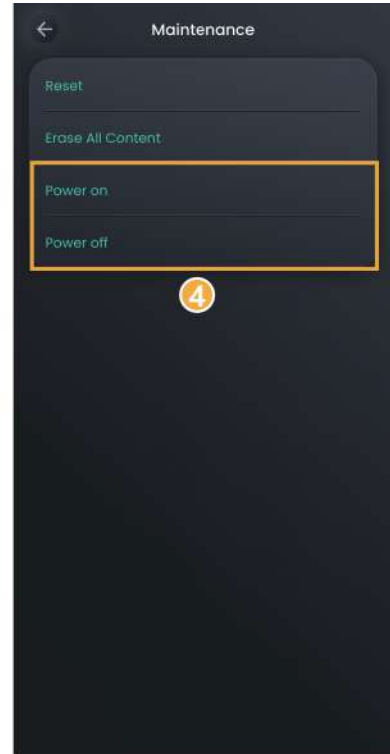
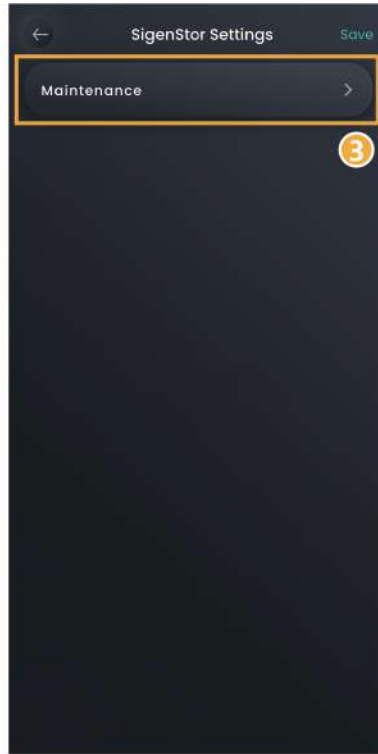

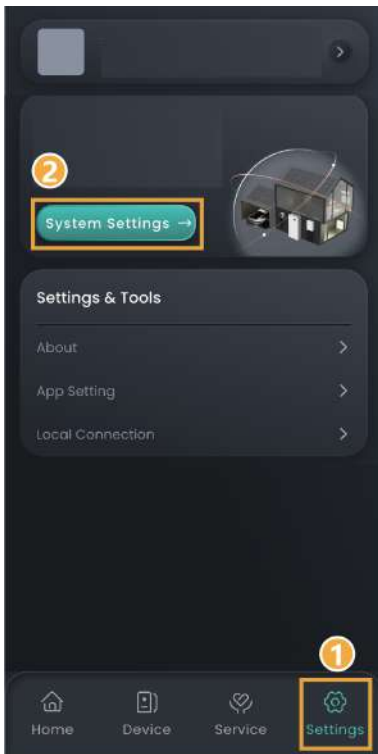

5.1.1 Remote Connectivity of the Device

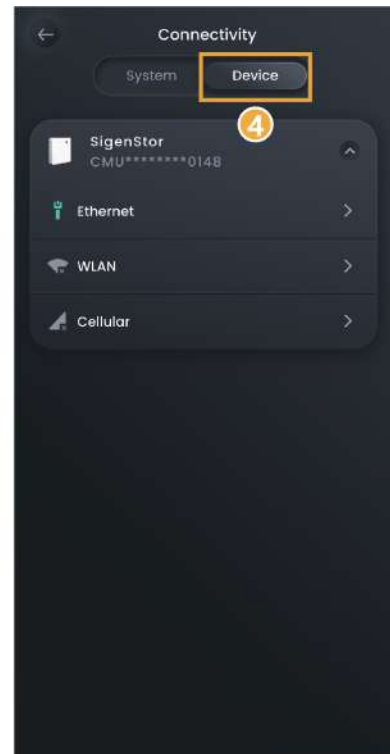
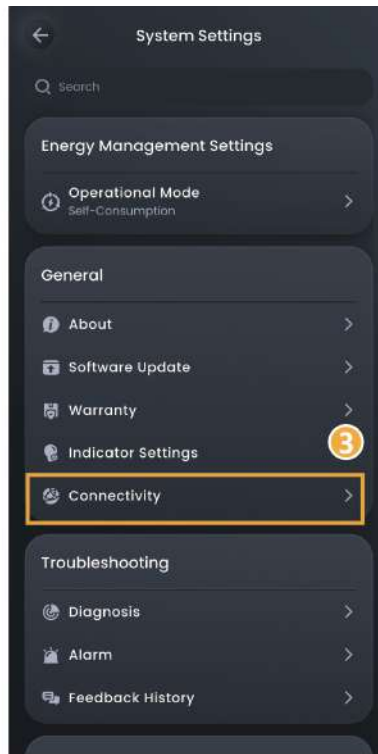

MSA1CM00071



No.	Parameter name	Description
1	Ethernet	<p>Display FE connection status.</p> <ul style="list-style-type: none"> ● MAC: Show MAC address. ● Ethernet <ul style="list-style-type: none"> □ Primary DNS: Primary DNS server for domain name resolution (non-editable). □ Secondary DNS: Secondary DNS server for domain name resolution (editable).(After configuring this parameter, it takes effect for Ethernet, WLAN, and Cellular.) ● Obtain IP address automatically: When set to , IP addresses are obtained automatically. When set to , users need to configure a static IP address. <ul style="list-style-type: none"> □ IP Address: FE IP address of the current SigenStor/SigenStack Unit. □ Gateway: FE gateway of the current SigenStor/SigenStack Unit. □ Subnet Mask: FE subnet mask of the currentSigenStor/SigenStack Unit. ● FE network connection parameters are set to DHCP by default. If you need to modify them, follow these steps: <ol style="list-style-type: none"> 1. Configure a functional WLAN for internet access, or insert the Sigen Comm-Mod. 2. After "WLAN" or "Cellular" shows "Connected", unplug the network cable used for connectivity from the device. 3. Set "Obtain IP address automatically" to , then modify the parameters. 4. Re-plug the network cable used for connectivity into the device.
2	WLAN	<p>Display WLAN connection status.</p> <ul style="list-style-type: none"> ● MAC: Show MAC address. <p>If it shows "Not Connected" here, but you intend to use WLAN for network connectivity, please follow the instructions below:</p> <ul style="list-style-type: none"> ● Before configuring WLAN communication, ensure that the antenna is installed on the device. ● Connecting to an unencrypted WLAN may result in network unavailability and is not recommended. ● When the device can only use WLAN for network connectivity, do not switch to other wireless router WLANs. ● Tap "Go Set Up" to configure the WLAN network.
3	Cellular	<p>Display 4G connection status.</p> <p>If it shows "Not Connected" here, but you intend to use 4G for network connectivity, please follow the instructions below:</p> <ul style="list-style-type: none"> ● Before configuring 4G communication, ensure that the Sigen CommMod is inserted. ● When using 4G communication, you can view the current monthly data usage.



5.2 Sigen EV DC Charging Module Setting



MSA1CM00076

No.	Parameter name	Description
1	Charging Record	Click to view charging history.
2	Schedule	If the connected car supports the scheduled Charging function, you can set the scheduled charging and discharging periods.

Charging Preference

No.	Parameter name	Description
1	Charging Mode	<ol style="list-style-type: none"> 1. Fast Charging: Significantly increases the charging rate, providing a quick charge to replenish a large amount of power in a short time. 2. PV Surplus Charging: Utilizes excess energy from the photovoltaic system to charge the battery. 3. (Optional) Bi-directional Charging: Use SigenStor EVDC as additional "energy storage" to participate in the scheduling of the entire power station, discharging to household devices or the grid. <ul style="list-style-type: none"> ● After enabling the V2X function, this mode can be set. For specific operation steps, refer to (Optional) V2X Function Settings. ● Battery Boost: When set to , it can charge using the home battery. ● Cut-OFF SOC: When Battery Boost is enabled, the battery will stop charging the Sigen EV DC charging module if the actual SOC is less than the set parameter. ● Surplus PV priority: Select the device and drag it up or down to modify the device's priority. ● Set the discharge stop SOC threshold for the Electric Vehicle. Discharging will be stopped when the vehicle's SOC falls below the set value.
2	Charging Setting	<ul style="list-style-type: none"> ● Setting the maximum charging power permitted for Sigen EV DC Charging Module. ● Set the charging stop SOC parameter. Charging will be stopped when the EV's SOC exceeds the set value.
3	OCPP Settings	<ul style="list-style-type: none"> ● OCPP Status: Display explicit OCPP connection status. ● When it is set to , the Sigen EV DC Charger can connect to the OCPP server, and users can select the OCPP platform from the URL drop-down menu.
4	Authorization	Set the charging authentication. When it is set to  , unauthenticated charging is allowed.
5	Card Management	Bind a Sigen RFID card.
6	My Vehicle	Tap to add or edit electric vehicle information.

Charger Settings

Parameter name	Description
Maintenance	<ul style="list-style-type: none"> ● Reset: The device restarts. ● This will clear 5-minute performance data, alarms, hourly/daily/monthly/annual power generation records, operation logs, device information, etc. Proceed with caution.



For use and precautions of the Sigen EV DC Charging Module, refer to the Sigen EV DC Charging Module User Manual.

5.2.1 (Optional) V2X Function Settings

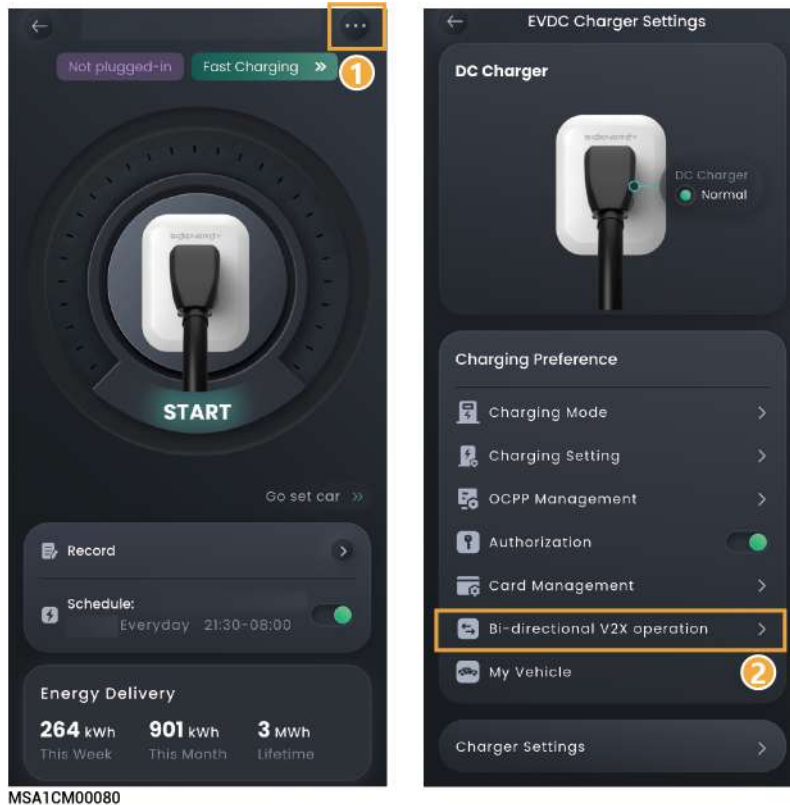
- After activating the V2X function, SigenStor EVDC can be used as additional "energy storage" to participate in power station scheduling, supplying power to household devices.
- When the SigenStor software version is the latest, V2X functionality is supported.



MSA1CM00080

- When activating the V2X function for the first time, tap "Bi-directional V2X operation", and you need to sign a risk acknowledgment agreement and fill in basic information such as vehicle model before setting "Bi-directional V2X operation" to .
- When "Authorization" is set to , and the charging connector is properly installed, you can set the discharge time period and power for SigenStor EVDC via "Add Manual Control". If SigenStor EVDC is discharging during the set time period and you want to force stop, tap "Stop Discharging".

5.3 Sigen EV AC Charger

In pure charging scenarios, only one Sigen EV AC Charger can be connected. In PV charging or PV storage scenarios, one SigenStor can connect up to two Sigen EV AC Chargers.

Pure charging application

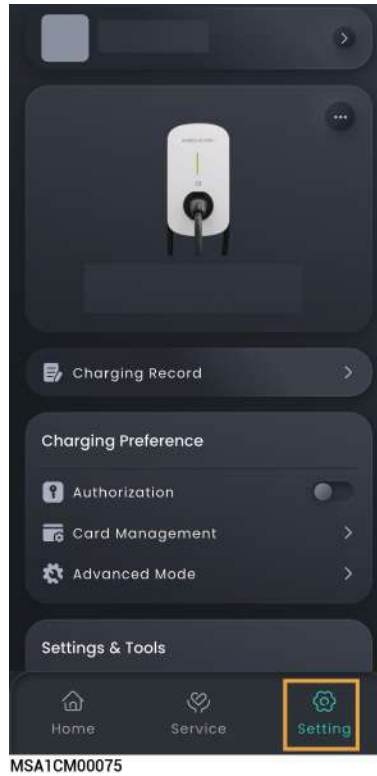

PV charging or PV storage & charging application



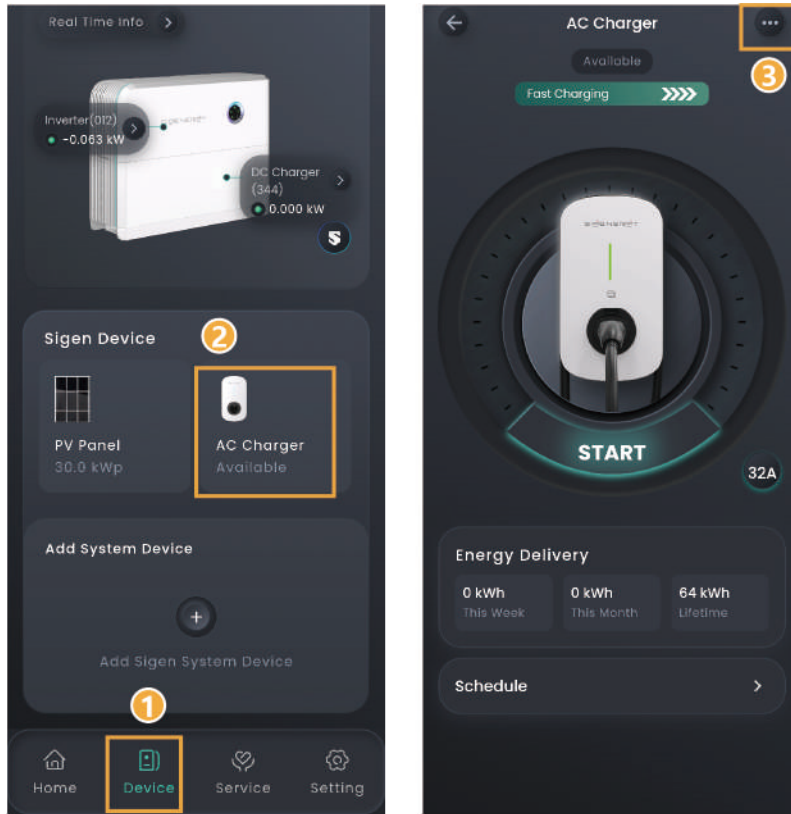

- To connect a Sigen EV AC Charger, you need to connect the FE network cable to SigenStor.
- To connect two Sigen EV AC Chargers, you need to connect them to the same WLAN network as SigenStor.





SSA1CM00070

Charging Preference

No.	Parameter name	Description
1	Schedule	If the connected car supports the scheduled Charging function, you can set the scheduled charging and discharging periods.
2	Charging Record	You can view the charging records.

No.	Parameter name	Description
3	Charging Mode	<p>Fast Charging</p> <p>Battery Boost: When set to , it allows charging from the home battery. Cut-OFF SOC: When Battery Boost is enabled, the battery will stop charging the Sigen EV AC charger if the actual SOC is less than the set parameter.</p> <p>PV Surplus Charging</p> <p>Battery Boost: When set to , it allows charging from the home battery. Cut-OFF SOC: When Battery Boost is enabled, the battery will stop charging the Sigen EV AC charger if the actual SOC is less than the set parameter. Grid Charging: When set to , it allows setting the rated power of the connected device. The maximum power from the grid: In PV surplus charging mode, this value indicates the maximum power that can be drawn from the grid when PV power is insufficient. Surplus PV priority: If this parameter is set, it will redirect to the priority page for PV power generation.</p> <p>Sigen AI Mode:</p> <p>To use this mode, please refer to the activation steps for Sigen EV AC Charger activates Sigen AI Mode. By integrating local peak/off-peak electricity prices, weather data, and user consumption habits, it provides customized smart charging solutions and enables intelligent scheduling throughout the entire charging process, maximizing cost savings and delivering a convenient experience for users.</p>
4	OCPP Setting	<ul style="list-style-type: none"> ● OCPP Status: Display explicit OCPP connection status. ● When it is set to , Sigen EV AC Charger can be connected to the OCPP server, and users can select the OCPP platform from the URL drop-down list.
5	Authorization	<p>Set the charging authentication. When it is set to , unauthenticated charging is allowed.</p>
6	Card Management	<p>Bind a Sigen RFID card.</p>

No.	Parameter name	Description
7	Advanced Mode	<ul style="list-style-type: none"> ● Output Mode: Select single-phase or three-phase output as needed. ● Dynamic load management: When Power Sensor is installed in the networking and is not in off-grid state, and if it is set to , Sigen EV AC Charger will support dynamic load management (DLM). Sigen EV AC Charger quickly and intelligently regulates the charging current (power) by comparing the power at the grid-connection point reported by the Power Sensor with the "Rated Household Circuit Breaker Current" set by the installer when creating new systems to prevent the Household Circuit Breaker in the distribution panel from being disconnected. ● Home air circuit breaker rated current: The current specification of the household circuit breaker controls the charging power of the AC pile so that the household current is less than the set value. ● Allow charging when off-grid: When it is set to , charging is allowed during off-grid operation.
8	Indicator Settings	Click to set the LED light on/off for the Sigen EV AC Charger.
9	Connectivity	<p>Ethernet Displays the connection status of Fast Ethernet. For Fast Ethernet, network parameters are automatically obtained using a DHCP server. To edit parameters, do the following: Configure a WLAN that can access the internet or insert a 4G SIM card. Wait until "WLAN" or "Cellular" is displayed as "Connected," and disconnect the network cable. Set "Obtain IP address automatically" to  and edit parameters. Re-connect the network cable to the device.</p> <p>WLAN Displays the connection status of WLAN. If the connection status is displayed as "Not connected" and you want to use the WLAN to access internet, select a WLAN hotspot supporting 2.4 GHz band.</p> <p>Notes: Non-encrypted WLAN is not recommended as it may lead to Internet access failure. When WLAN is the only connection path for the devices to access the internet, switching WLAN to any other wireless router will be prohibited.</p> <p>Cellular Displays the connection status of 4G network. If the connection status is displayed as "Not connected," and you want to use the 4G network to access the internet, ensure that you insert the 4G SIM card. When 4G is used for communication, users can view the monthly traffic usage and set a traffic usage threshold for each month.</p>

Charger Settings

No.	Parameter name	Description
1	Grid Code	Specifies a grid code based on the country/region when devices are used.
2	Ground mode	Specifies the grounding type according to local grid type.
3	Home air circuit breaker	Specifies the rated current according to the home main incoming circuit breaker within the distribution panel.
4	Input circuit breaker rated current	Specifies the rated current according to circuit breakers connected to devices in the distribution panel.
5	Charging pile type	You can choose the charging pile type.
6	Phase Type	Specifies the phase type according to actual wiring.
7	Maintenance	<ul style="list-style-type: none"> ● Reset: The device restarts. ● This will clear 5-minute performance data, alarms, hourly/daily/monthly/annual power generation records, operation logs, device information, etc. Proceed with caution.

For use and precautions of the Sigen EV AC Charger, refer to the Sigen EV AC Charger User Manual.

Charging Current Adjustment

A higher output current value results in greater charging power.

Manual Adjustment

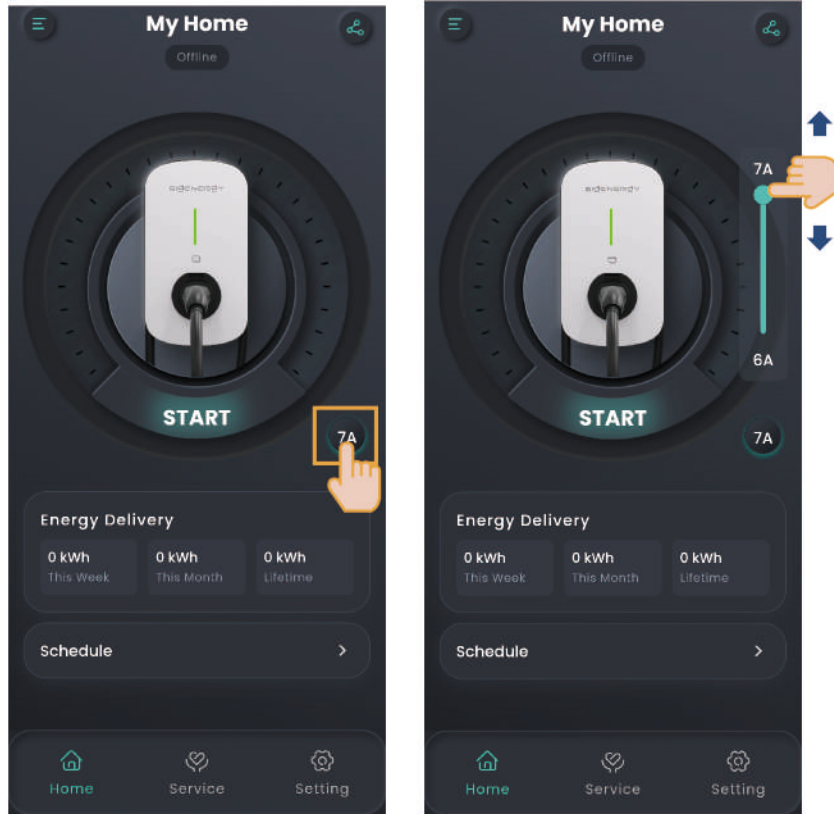

SSA1CM00069

DLM Automatic Adjustment

Power Sensor must be installed in the system station.

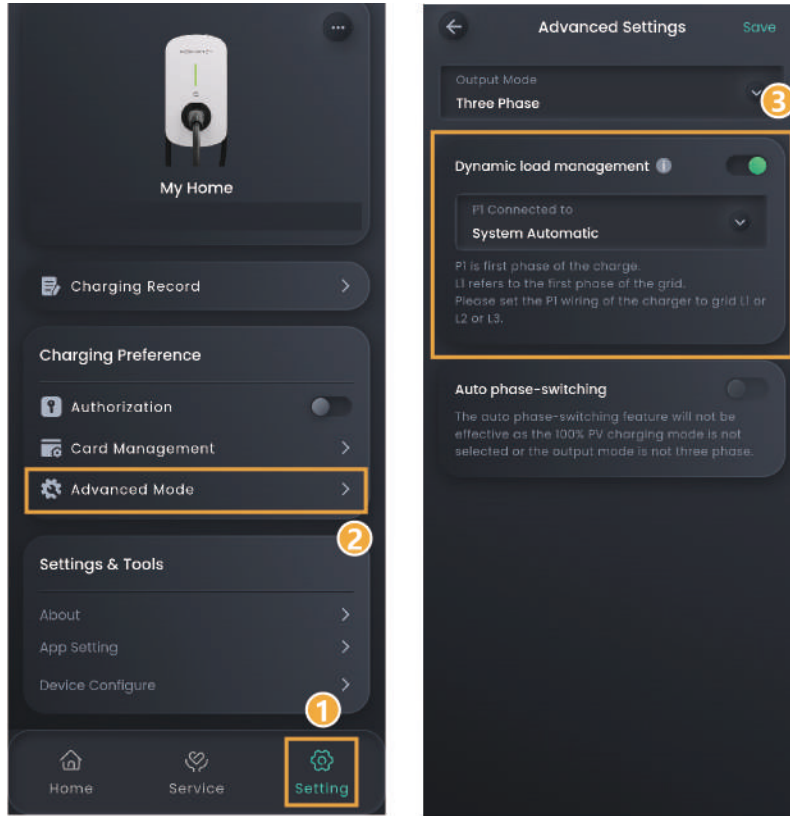

SSA1CM00069

Charging/Stop Charging Settings

Pure Charging Scenario

Click "START" or "STOP" on the "Home" interface.

PV Charging or PV+Storage+Charging Scenario

Click "AC Charger" on the "Device" interface, then click "START" or "STOP".

5.3.1 Sigen EV AC Charger activates Sigen AI Mode

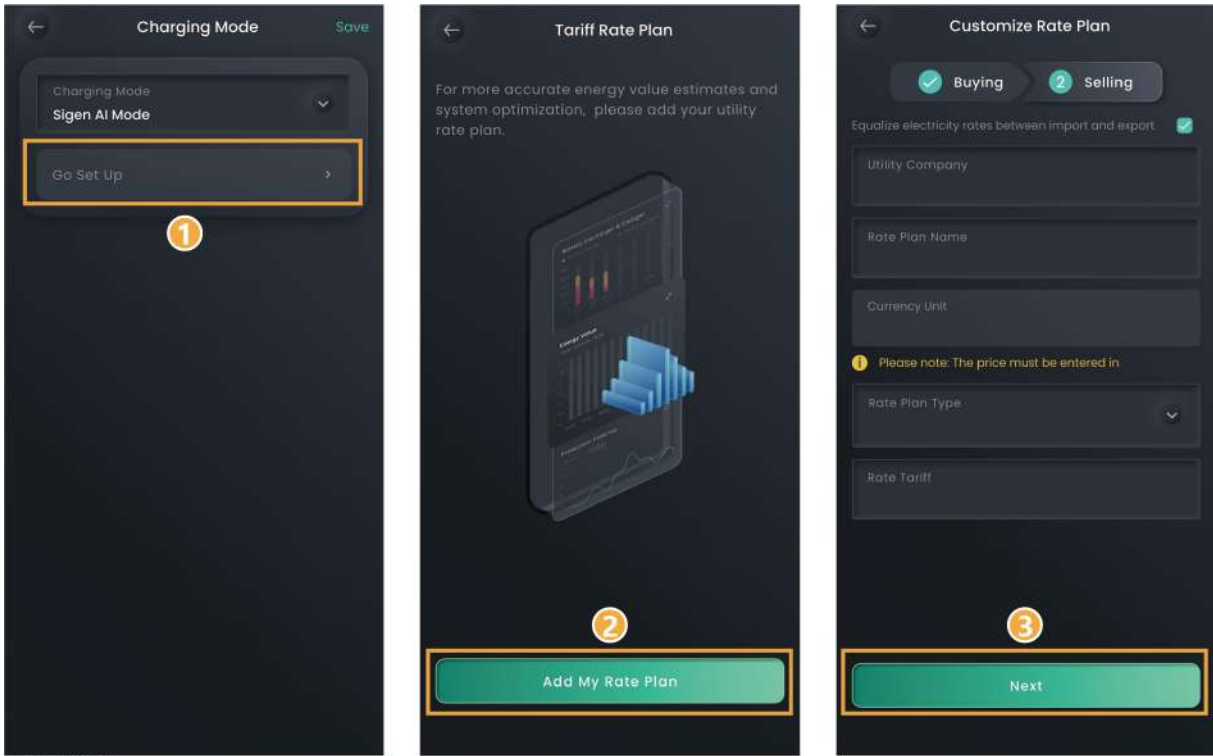

MSA1CM00100

No.	Parameter Name	Description
1	My Car	<ul style="list-style-type: none"> At least one electric vehicle must be added. Multiple EVs can be added, with one set as the preferred vehicle. Battery Capacity: Set the battery capacity.
2	Preferences	Target Charged: The target charging level. The vehicle will reach this level before the Ready By Time.
3	Explained	Ready By Time: The scheduled completion time for charging. The vehicle will reach the Target Charged level by this time.
4	Battery Boost	When set to  , the home battery will supply power to the Sigen EV AC Charger.
5	Cut-OFF SOC	When Battery Boost is enabled, charging from the home battery to the Sigen EV AC Charger will stop if the actual SOC falls below the set value.
6	My Rate Plan	Click to view the electricity rate plan.

Chapter 6 Add Sigen/Third-Party Device

Tips

- If you use our products (excluding SigenMicro), the system will automatically recognize and connect them. You can view device information on the "Device" screen.
- This section describes how to connect SigenMicro and third-party device.

6.1 SigenMicro

Tips

- This function is supported when the SigenStor software version is the latest.
- To add SigenMicro to the power station, manually add it via the App after the physical wiring of SigenMicro is completed.

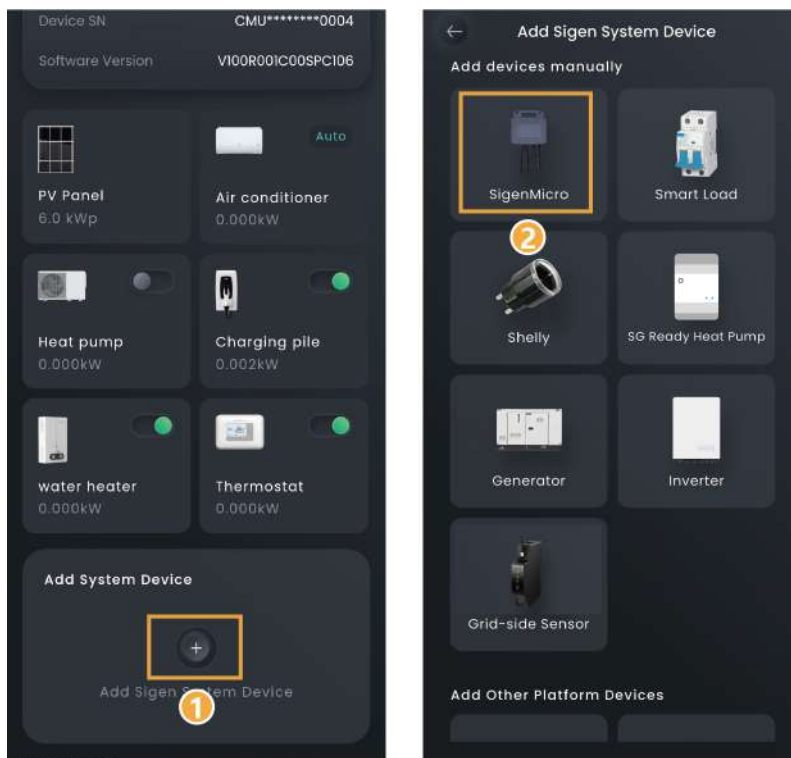

SSA1CM00088

6.2 Smart load

Tips

- After adding the Smart Load to the App, you can switch the Smart Load on and off through the App. Alternatively, the system can remotely control the equipment on and off based on the actual running conditions and the SOC threshold you set.
- If you cannot locate the icon of the connected device, for example, an immersion heater, select "Other" and connect it. You can check the connected smart load on the "Device" screen.

Method 1: Connecting using Gateway

Tips

- Before connecting the smart load, ensure that a Gateway has been configured in the network and that the smart load port is not connected to a generator.
- The number of Smart Loads that can be connected is determined by the supported capacity of the Gateway.

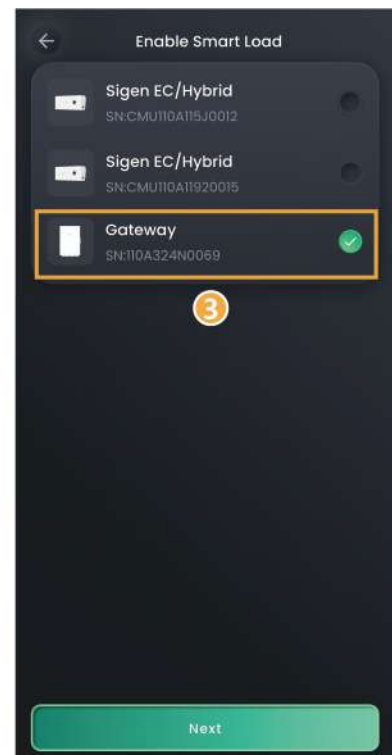
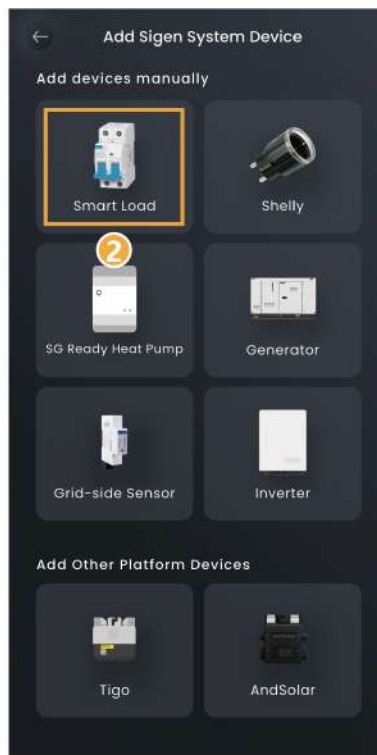
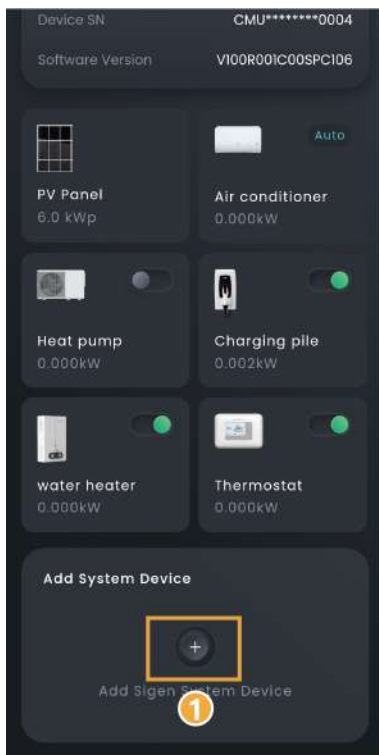

Method 2: Connecting using Sigen Inverter

Tips

- Before connecting smart loads, please ensure that a Sigen inverter has been configured in the network and that the DO port is not connected to a generator.

Tips

- The number of connectable smart loads is determined by the maximum number of smart loads supported by the Sigen inverter.

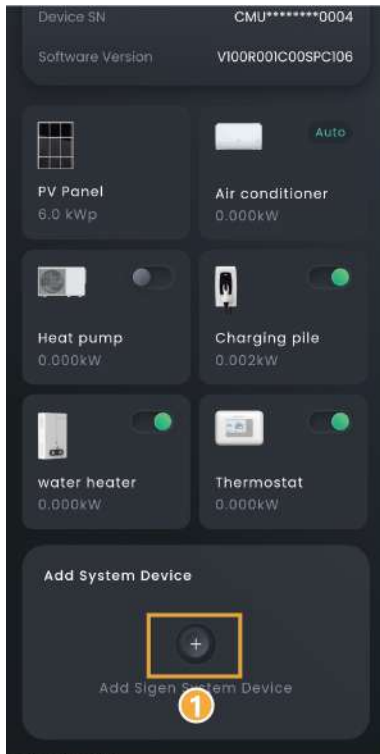

SSA1CM0072

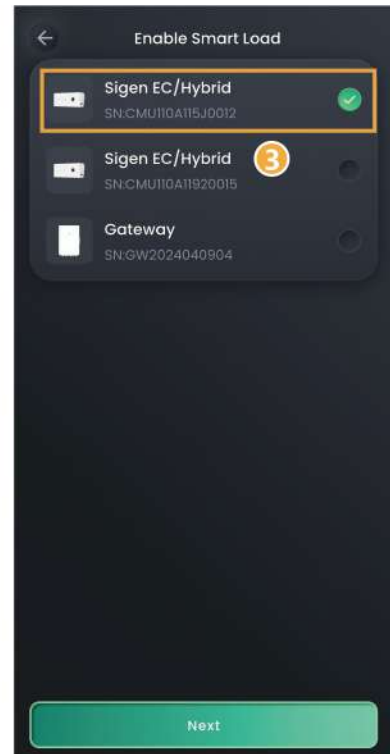
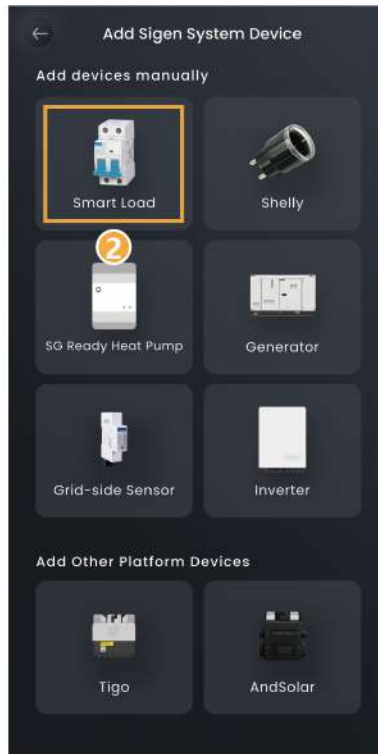

Method 3: Connecting using Shelly

Tips

If Shelly is not configured with the same WLAN as SigenStor, you can connect to Shelly through Bluetooth on your mobile phone. Configure Shelly to the WLAN where SigenStor is located, and establish communication.

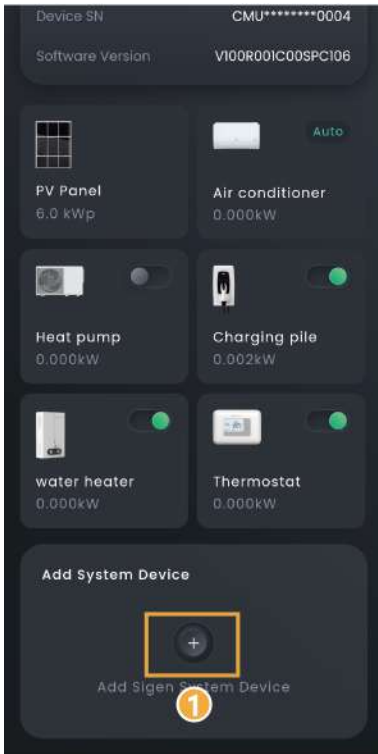

SSA1CM00072

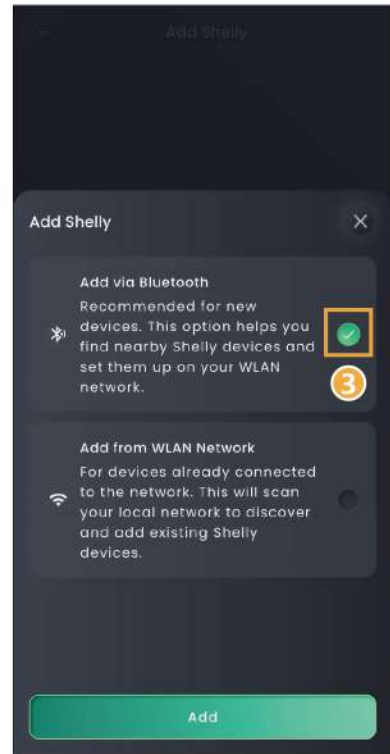
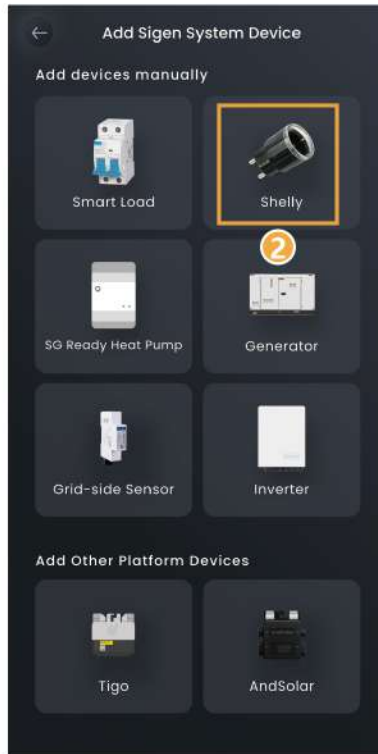

Tips

If Shelly is already configured with the same WLAN as SigenStor, you can connect the phone, SigenStor, and Shelly to the same WLAN to establish communication.

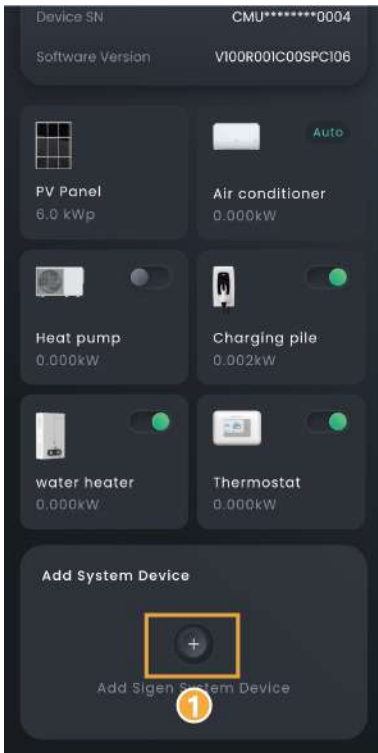

SSA1CM00072

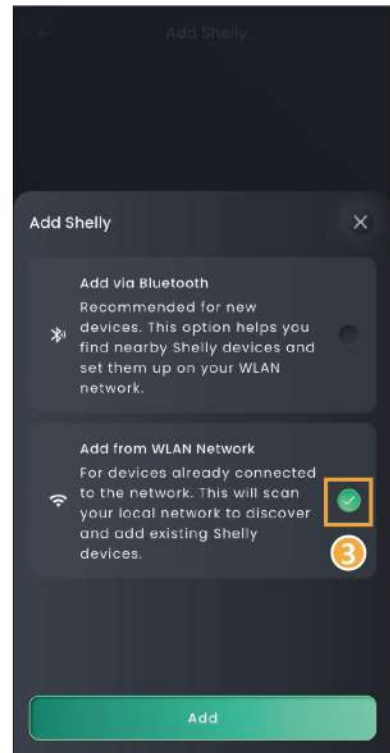
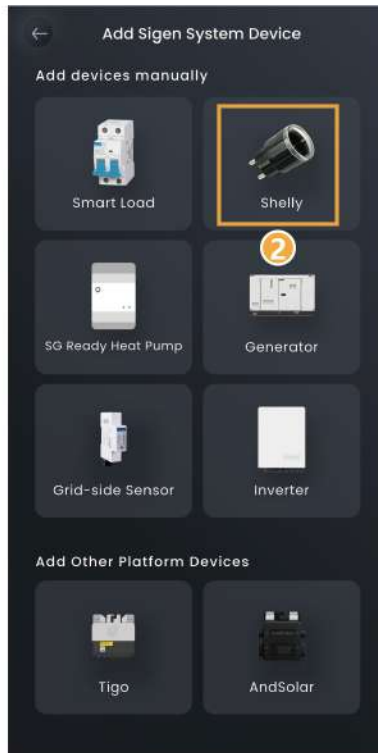

Tips

- A power station can support a maximum of 20 Shelly connections.
- Shelly can connect to the router through a network cable or WLAN. For related information about Shelly, please refer to the user manual and specifications of the corresponding Shelly model.
- Shelly consists of a smart socket, a smart relay, and a smart meter. It is used for power and energy statistics and can be used to remotely control smart loads.
- The following table lists the Shelly models supported by the Sigen household series inverter. Please match your model according to the actual situation.

No.	Product Type	Model Number	Recommended firmware versions supporting Shelly	Maximum supported load current
1	Smart plugs	Shelly Plug S Gen3	1.2.2, 1.2.3	AC power supply: 12A
2	Smart plugs	Shelly Outdoor Plug S Gen3	1.2.3-matter22	AC power supply: 12A
3	Smart plugs	Shelly Plus Plug S	1.0.7, 1.3.3, 1.4.4	AC power supply: 12A
4	Smart plugs	Shelly Plus Plug UK	1.0.7, 1.3.3, 1.4.4	AC power supply: 13A
5	Smart relays	Shelly 1PM Gen3	1.2.2, 1.3.3	AC power supply: 16A DC power supply: 10A
6	Smart relays	Shelly 2PM Gen3	1.2.2, 1.3.3	AC power supply: 10A per channel, 16A total
7	Smart relays	Shelly 1PM Mini Gen3	1.3.3, 1.4.4, 1.5.0-beta1	AC power supply: 8A
8	Smart relays	Shelly Plus 1PM	1.3.3, 1.4.4, 1.5.0-beta1	AC power supply: 16A DC power supply: 10A
9	Smart relays	Shelly Plus 2PM	1.3.3, 1.4.4, 1.5.0-beta1	AC power supply: 10A per channel, 16A total
10	Smart relays	Shelly Pro 1PM	0.10.2-beta1, 1.4.4, 1.5.0-beta1	AC power supply: 16A per channel
11	Smart relays	Shelly Pro 2PM	0.10.2-beta1, 1.4.4, 1.5.0-beta1	AC power supply: 16A per channel, 25A total
12	Smart relays	Shelly Pro 4PM	0.10.2-beta1, 1.4.4, 1.5.0-beta1	AC power supply: 16A per channel, 40A total
13	Smart relays	Shelly Pro 1	0.10.2-beta1、 1.3.3	AC power supply: 16A
14	Smart relays	Shelly Pro 2	1.3.2-g34c651b、 1.3.3	AC power supply: 16A per channel, 25A total
15	Smart relays	Shelly Pro 3	1.3.0-ga3fdd3d、 1.3.3	AC power supply: 16A per channel, 48A total
16	Smart relays	Shelly 1PM Gen4	1.5.99-g4prod1、 1.6.2	AC power supply: 16A DC power supply: 10A
17	Smart relays	Shelly 1PM Mini Gen4	1.5.99-g4prod1、 1.6.2	AC power supply: 8A

No.	Product Type	Model Number	Recommended firmware versions supporting Shelly	Maximum supported load current
18	Smart relays	Shelly 1 Gen4	1.5.99-g4prod1、 1.6.2	AC power supply: 16A DC power supply: 10A
19	Smart relays	Shelly Plus 1	1.4.0-gb2aeadb、 1.6.2	AC power supply: 16A DC power supply: 10A
20	Smart relay	Ogemray Smart relay 25A	1.5.0, 1.7.1	AC power supply: 25 A
21	Smart relay	Shelly 1 Mini Gen4	1.5.99-g4prod1, 1.7.4	AC power supply: 8A DC power supply: 5A
22	Single-phase electricity meter	Shelly Pro EM - 50	1.3.3,1.7.1	Supports a maximum current of 50A
23	Single-phase electricity meter	Shelly Pro EM	1.3.3,1.7.1	Supports a maximum current of 50A
24	Three-phase electricity meter	Shelly Pro 3EM	1.7.0,1.7.1	Supports a maximum current of 120A
25	Three-phase electricity meter	Shelly Pro 3EM 3CT 6	1.3.3,1.7.1	Supports a maximum current of 63A
26	Three-phase electricity meter	Shelly Pro 3EM - 400	1.3.99,1.7.1	Supports a maximum current of 400A
27	Three-phase electricity meter	Shelly 3EM - 63W Gen3	1.3.3,1.7.1	Supports a maximum current of 63A

Control Mode

On the device interface, click the Smart load you want to configure to set the Smart load control mode.

No.	Parameter name	Description
1	Manual Control	<ul style="list-style-type: none"> When it is displayed as In Use, you can turn on and off the Smart Load through  on the App. When displayed as Disable, You can click "Enable Manual" to switch to manual mode.
2	Auto (Time-based)	<ul style="list-style-type: none"> When displayed as In Use, it indicates automatic control mode. You can modify or add a schedule. When displayed as Disable, you can click "Set a Schedule" → "Yes, save and use" to switch to automatic mode.

No.	Parameter name	Description
3	Schedule	<p>Energy Source Control: Set the Energy Source Type. The following three modes can be set:</p> <ol style="list-style-type: none"> Depends on System: In this mode, the Smart load activates and deactivates according to the preset schedule. Surplus PV Only: In this mode, the Smart load activates/deactivates based on configured power thresholds. Solar Producing Source priority can be set. Battery Level Control: In this mode, the load is controlled based on battery SOC thresholds. <ul style="list-style-type: none"> Battery Boost: When set to , home batteries charge Smart Home Device. Starting Power: Set the starting power of the Smart load. Rated Power: Set the rated power of the Smart Home Device, which can be checked on the Smart load's label. Device Activation Threshold: The Smart load will activate when the actual SOC is greater than the set parameter. Device Deactivation Threshold: The Smart load will deactivate when the actual SOC is less than the set parameter.
4	Ready by	<ul style="list-style-type: none"> Activation For: Total running time. Before the time set in Ready By, if the running time on that day is less than the set value, the load will be turned on. Be Ready By: Set the running time. It is used in conjunction with the total running time.
5	Resume Schedule	If a schedule has been added, you can click to delete the schedule parameters.

Smart Load Settings

On the device interface, click the Smart load you want to configure → click  in the upper right corner to set the smart load parameters.

No.	Parameter name	Description
1	General Settings	Set the smart load type, name, and assigned room.

No.	Parameter name	Description
2	Operation Settings	<p>PV Excess Setting</p> <ul style="list-style-type: none"> Starting Power: Set the starting power of the Smart load. Rated Power: Set the rated power of the Smart load, which can be checked on the Smart Home Device's label. <p>Minimum Running Time: Set the minimum running time for the Smart load.</p> <p>Backup Management (When configuring the Gateway in the network setup, this parameter is displayed.)</p> <ul style="list-style-type: none"> When Essential Load is set to , the SOC for load startup and shutdown can be configured. Cut-in: The Smart load will activate when the actual SOC is greater than the set parameter. Cut-off: The Smart load will deactivate when the actual SOC is less than the set parameter.
3	Remove smart load	Click to remove the smart load.

6.3 Grid-side Sensor

Tips

- In anti-backflow scenarios, power stations require the installation of a grid-connection point electricity meter.
- The graphical interface displayed may vary depending on the meter model. Please refer to the actual display in the App.

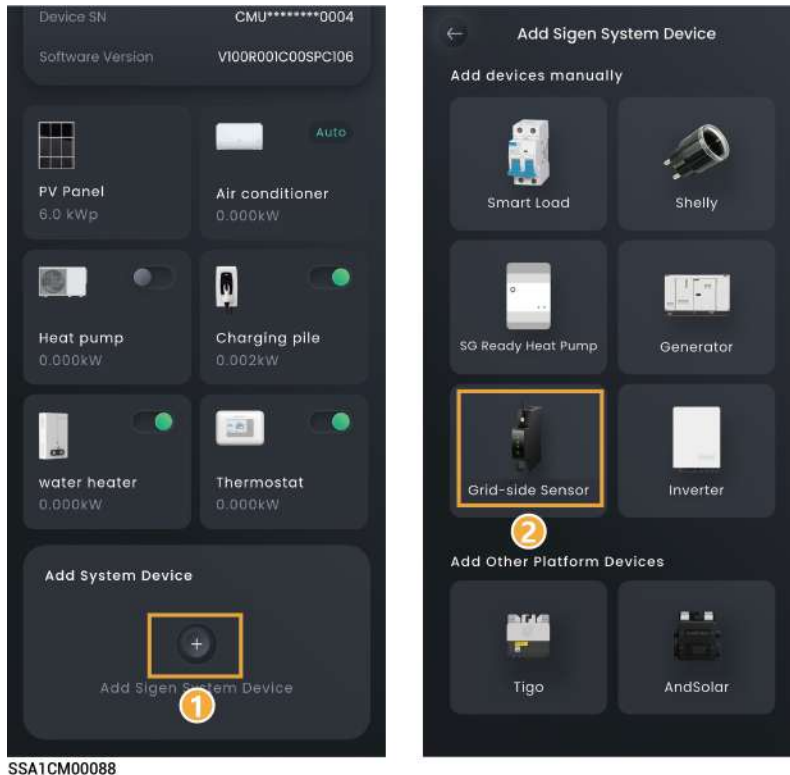

Add WLAN Meter

- Only power stations with SigenMicro series products can add grid-connection point electricity meters.
- The WLAN connected to the electricity meter must be consistent with the WLAN connected to the power station.

Add RGM Meter

- Only power plants in the US region can add the RGM meter.
- If adding the RGM meter via the inverter's RS485 interface or the LoadHub's RS485 interface, the operation must be performed through the App. For information regarding the inverter or LoadHub, please consult the "Installation Guide" for the corresponding model.

Meter Settings

- Only available for commercial and industrial (C&I) power stations.

- Due to differences in actual site conditions, the voltage and current ratios between the primary side (high voltage, high current) and the secondary side (measurable by the meter) may vary. Configuring this parameter allows the actual values from the primary side to be proportionally converted into standard values measurable on the secondary side.

No.	Parameter	Description
1	Meter Parameters	<ul style="list-style-type: none"> ● CT ratio: Scales down a large current proportionally to a smaller current. (CT ratio = Primary current / Secondary current) ● PT ratio: Scales down a high voltage proportionally to a lower voltage. (PT ratio = Primary voltage / Secondary voltage) ● Actual primary side power = Secondary side measured value × CT ratio × PT ratio <p>Example: Assume an energy meter measures a secondary side power of 100W, with the following settings:</p> <ul style="list-style-type: none"> ● CT ratio = 600A / 5A = 120x ● PT ratio = 10000V / 100V = 100x ● Actual primary side power = 100W × 120 × 100 = 1,200,000W (1.2MW)

6.4 Generator

- Before connecting a diesel generator, please ensure that the Gateway that can be connected to the diesel generator has been configured in the networking and connected correctly. For details about the Gateway, please refer to the respective Installation Guide.
- If the Gateway features a Smart Port interface, the generator card will be displayed in the App interface.
- After connecting the generator to the Gateway, users must add the generator via the App to access and configure generator-specific parameters.

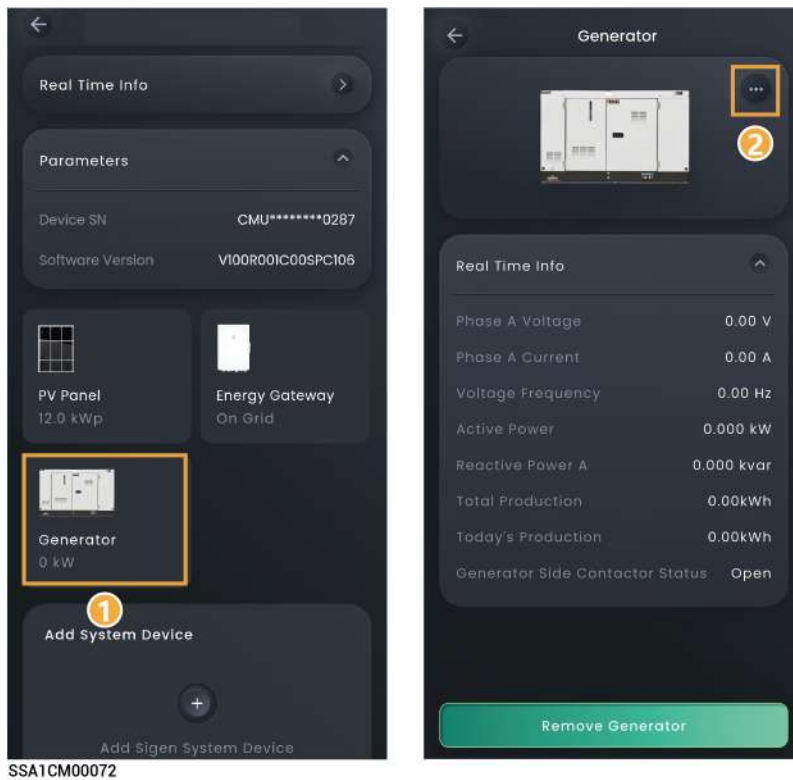

Manual start by operating the generator's switch



two - wire – start



In this mode, you must switch on and off the system on the generator side.

No.	Parameter name	Description
1	Rated Power	Sets the rated power of the diesel generator.
2	Maximum Power Duty	To guarantee the optimal functioning status of the system, you are advised to control the output power of the diesel generator not more than 80%.
3	Minimum Power Duty	To ensure that the diesel generator does not run at no-load, it is suggested to control the output power of the generator. The recommended default value is 0%.

No.	Parameter name	Description
4	Battery Charging Cut-off SOC for Generator	When the SOC of the battery pack is lower than the "Battery Charging Cut-off SOC for Generator" setting, the diesel generator will charge the battery pack to the set value.

In this mode, you can start and stop the diesel generator in the App, or the diesel generator can start or stop automatically.

No.	Parameter name	Description
1	Operating Mode	<ul style="list-style-type: none"> ● Manual ● Auto
2	Cooling Enable	After enabling the generator cooling function, the control system will de-energize the generator contactor via the DO signal to ensure a stable shutdown.
3	Generator Start	In "Manual" mode, when it is set to  , you can start or stop the generator using the  icon in the App.
4	Rated Power	Sets the rated power of the diesel generator.
5	Maximum Power Duty	To guarantee the optimal functioning status of the system, you are advised to control the output power of the diesel generator not more than 80%.
6	Minimum Power Duty	To ensure that the generator does not run at no-load, it is suggested to control the output power of the generator. The recommended default value is 0%.
7	Battery Charging Cut-off SOC for Generator	When the SOC of the battery pack is lower than the "Battery Charging Cut-off SOC for Generator" setting, the diesel generator will charge the battery pack to the set value.
8	Off-Grid Switch Params	<ul style="list-style-type: none"> ● Over-voltage Transfer Point: Over-voltage threshold for grid/generator transfer when generator is connected. ● Under-voltage Transfer Point: Under-voltage threshold for grid/generator transfer when generator is connected. ● Over-frequency Transfer Point: Over-frequency threshold for grid/generator transfer when generator is connected. ● Under-frequency Transfer Point: Under-frequency threshold for grid/generator transfer when generator is connected.
9	Exercise	<p>In "Auto" mode, when it is set to , the startup mode can be set.</p> <ul style="list-style-type: none"> ● Duration: Set the runtime duration. ● Interval: Set the scheduled start interval. ● Day In Week: Set the scheduled start date. ● Start Time: Set the scheduled start time.

No.	Parameter name	Description
10	Load Condition	<p>In "Auto" mode, when it is set to , you can set the Load Power Measurement Type.</p> <ul style="list-style-type: none"> ● Total Load Power <ul style="list-style-type: none"> □ Generator Start Total Load Power Threshold: Total load power threshold for Generator start. When the total load power is greater than the threshold, the Generator is started. □ Generator Stop Total Load Power Threshold: Total load power threshold for Generator stop. When the total load power is less than the threshold, the Generator is stopped. ● Maximum Power Per-phase <ul style="list-style-type: none"> □ Generator Start Per-phase Load Power Threshold: The generator will start when the power per phase is greater than the set parameter. □ Generator Stop Per-phase Load Power Threshold: The generator will shut down when the power per phase is less than the set parameter.
11	Time of use	<p>In "Auto" mode, when it is set to , you can set a schedule to start the Generator.</p> <ul style="list-style-type: none"> ● Auto Start SOC: When the battery SOC is greater than the threshold, the Generator is started. ● Auto Stop SOC: When the battery SOC is less than the threshold, the Generator is stopped. ● Maximum Power Duty: To guarantee the optimal functioning status of the system, you are advised to control the output power of the Generator not more than 80%.

6.5 Third-party inverter

Method 1: Connecting using Gateway

- Only third-party inverters that not support off-grid functionality are allowed to connect.
- Before connecting to a third-party inverter, ensure that the third-party inverter is connected to the smart load circuit breaker of the Gateway. For connection details, refer to the Installation Guide of the respective product.
- On the "Device" screen, set related parameters based on the third-party inverter. Then, you can check detailed settings on the "Device" screen.

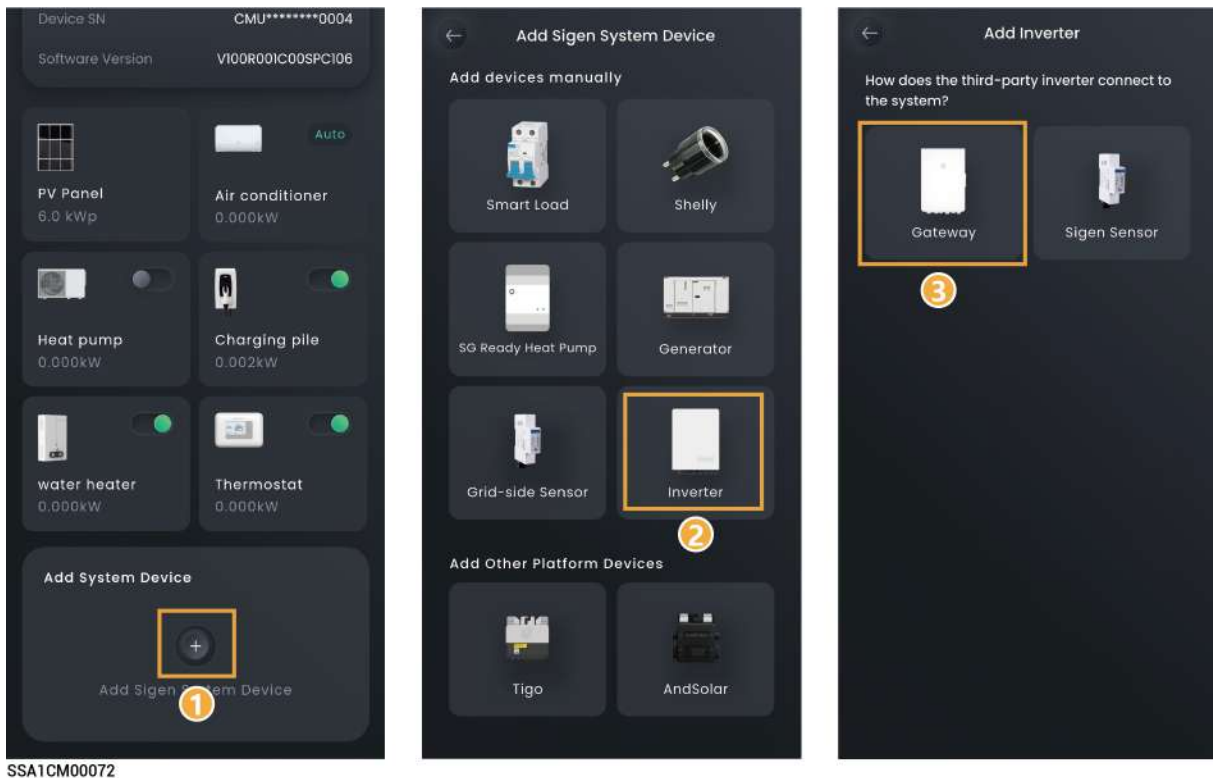

Method 2: Connecting using an electric meter

Before connecting to a third-party inverter, make sure that:

- The third-party inverter is properly connected to an electric meter which is purchased from our company.
- The electric meter is properly connected to the COM port of our inverter. For connection ports, please refer to the respective Installation Guide.
- A single or multiple third-party inverters can be selected. Please choose based on your actual situation.
- If an RGM meter is used, the corresponding device serial number (SN) must be selected according to the actual wiring configuration.

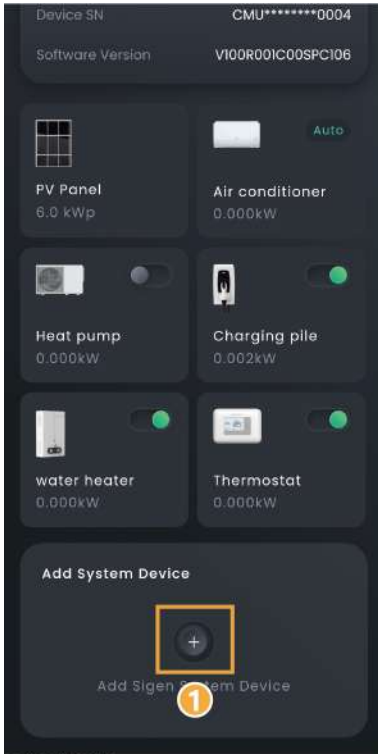

SSA1CM00072

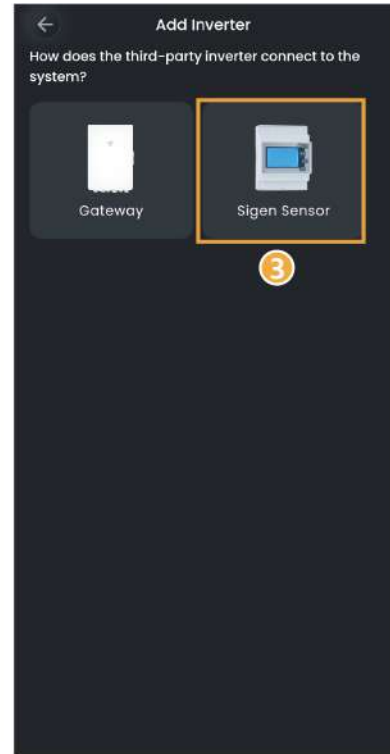
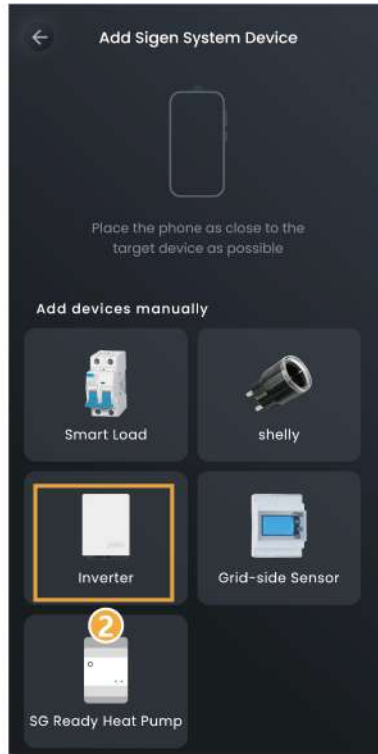

Add a single third-party inverter

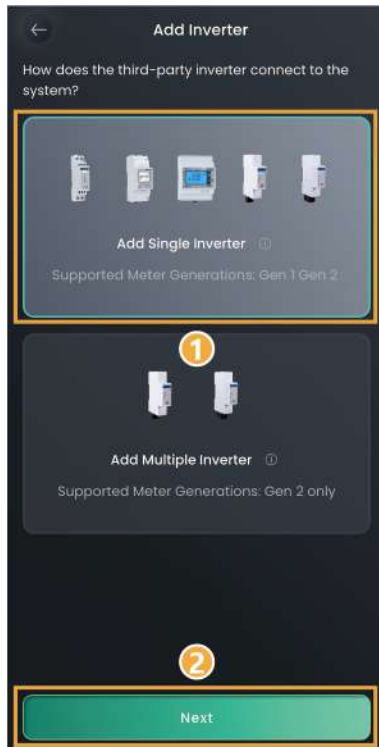

SSA1CM00072

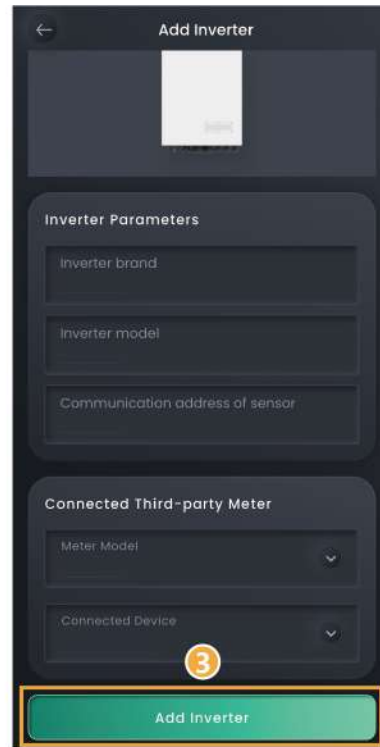

Add multiple third-party inverters



SSA1CM00072

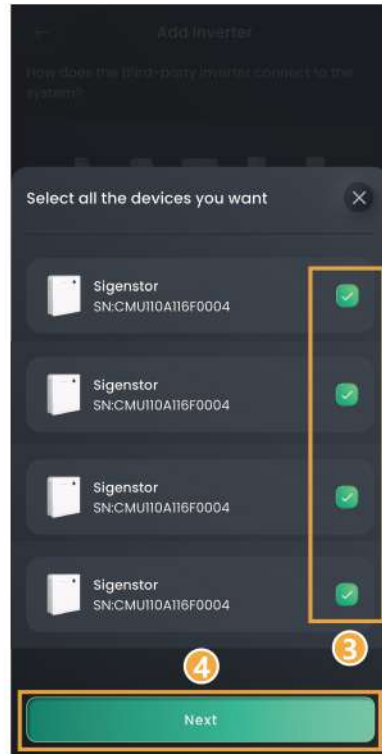
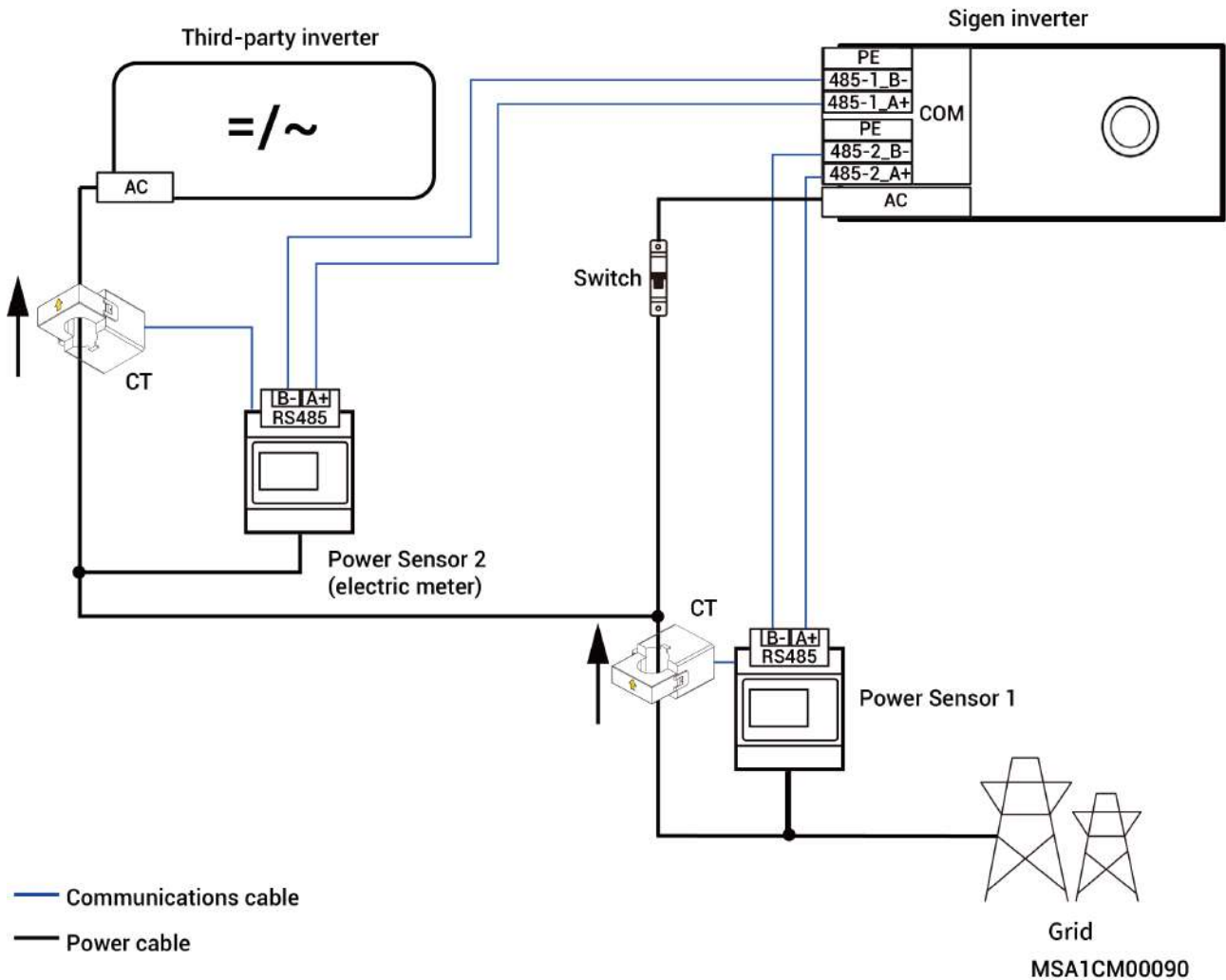



Diagram of third-party inverter wiring connections



- The diagram displays the connections among different cables of equipment. The specific ports shall be determined by actual equipment.
- On the "Device" screen, set related parameters based on the third-party inverter and the connected meter. Then, you can check detailed settings on the "Device" screen.
- In the off grid state, when the operating power of the third-party inverter is \leq (load usage power + Sigen inverter charging power), the third-party inverter can operate normally.
- In the off grid state, when the operating power of the third-party inverter is greater than (load usage power + Sigen inverter charging power), the third-party inverter will stop running.

6.6 SG heat pump

Before connecting to a heat pump, make sure that:

- The SG Ready Heat Pump has been properly connected to the DO port of the company's inverter, and the software version of the inverter enables users to connect the heat pump.
- "DO Custom Function Enable" in the "System Settings" menu has been set to .





SSA1CM00072

Control Mode

On the device interface, click the SG Ready Heat Pump to set the SG Ready Heat Pump control mode.

No.	Parameter name	Description
1	Manual Control	<ul style="list-style-type: none"> • When it is displayed as In Use, you can turn on and off the SG Ready Heat Pump through  on the App. • When displayed as Disable, You can click "Enable Manual" to switch to manual mode.
2	Auto (Time-based)	<ul style="list-style-type: none"> • When displayed as In Use, it indicates automatic control mode. You can modify or create a schedule. • When displayed as Disable, you can click "Set a Schedule" → "Yes, save and use" to switch to automatic mode.

No.	Parameter name	Description
3	Schedule	<p>Energy Source Control: Set the Energy Source Type. The following three modes can be set:</p> <p>Depends on System</p> <ul style="list-style-type: none"> Battery Boost: When set to , home batteries charge SG Ready heat pump. <p>Surplus PV Only</p> <ul style="list-style-type: none"> Starting Power: Set the starting power of the SG Ready heat pump. Rated Power: Set the rated power of the connected device, which can be checked on the SG Ready heat pump's label. <p>Battery Boost: When set to , the home battery charges the SG Ready heat pump.</p> <p>Battery Level Control</p> <ul style="list-style-type: none"> Device Activation Threshold: The SG Ready heat pump will activate when the actual SOC is greater than the set parameter. Device Deactivation Threshold: The SG Ready heat pump will deactivate when the actual SOC is less than the set parameter.
4	Ready by	<ul style="list-style-type: none"> Activation For: Total running time. Before the time set in Be Ready By, if the running time on that day is less than the set value, the SG heat pump will be turned on. Be Ready By: Set the running time. It is used in conjunction with the total running time.
6	Resume Schedule	If a schedule has been added, you can click to delete the schedule parameters.

SG Ready Heat Pump Settings

On the device interface, click SG Ready Heat Pump → Click  in the upper right corner to set the SG heat pump parameters.

No.	Parameter name	Description
1	General Settings	Set the SG Ready Heat Pump type, name, and assigned room.

No.	Parameter name	Description
2	Operation Settings	<p>PV Excess Setting</p> <ul style="list-style-type: none"> Starting Power: Set the starting power of the SG heat pump. Rated Power: Set the rated power of the connected device, which can be checked on the SG heat pump's label. <p>Minimum Running Time: Set the minimum running time for the device.</p> <p>Backup Management (When configuring the Gateway in the network setup, this parameter is displayed.)</p> <ul style="list-style-type: none"> When Essential Load is set to , the SOC for SG Ready Heat Pump startup and shutdown can be configured. Cut-in: The SG Ready Heat Pump will activate when the actual SOC is greater than the set parameter. Cut-off: The SG heat pump will deactivate when the actual SOC is less than the set parameter.
3	Remove SG Ready Heat Pump	Click to remove the SG Ready Heat Pump.

6.7 AndSolar

- Installing AndSolar can improve the conversion efficiency of photovoltaic systems.
- After adding AndSolar via the App, you can view its location and relevant parameters.

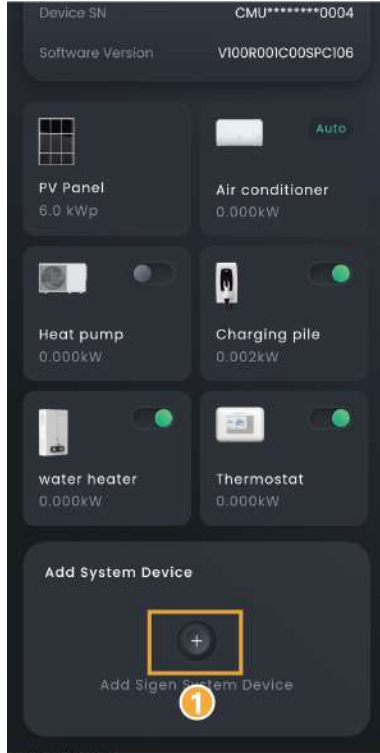

SSA1CM00072

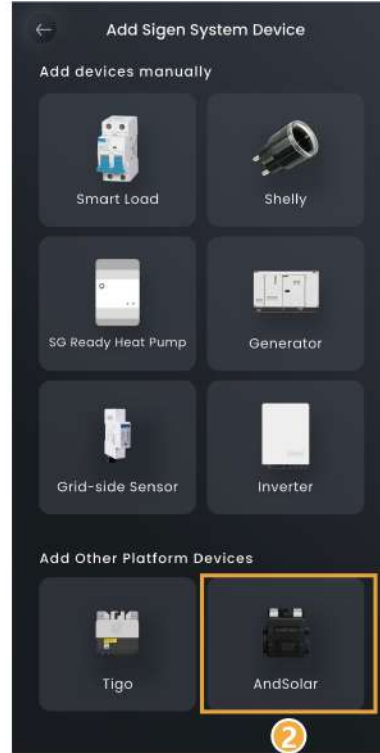

6.8 Environmental Monitor

Tips

Only commercial and industrial power stations can add an Environmental Monitoring Instrument (EMI).

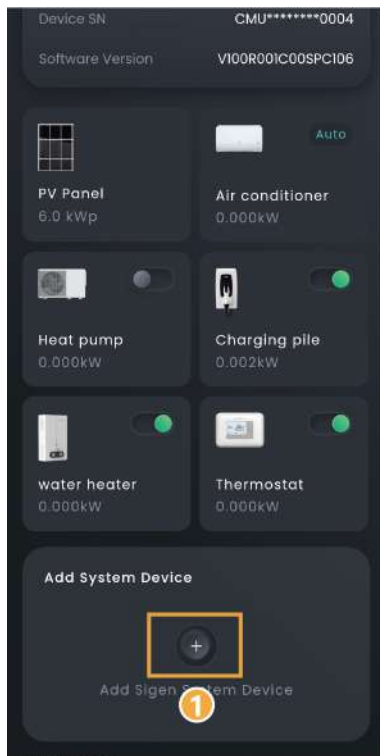

SSA1CM00088

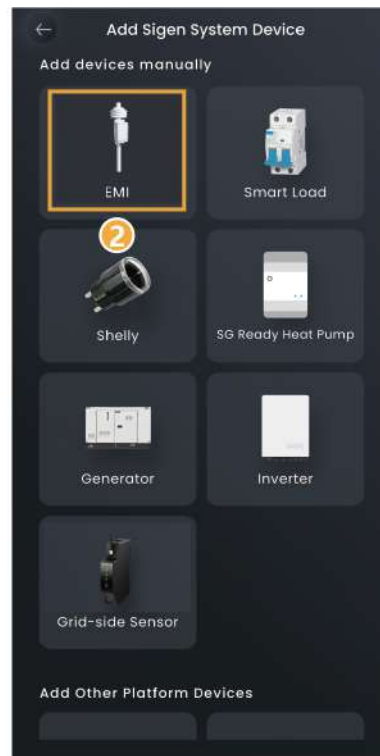

Chapter 7 Account Setting

Switch Accounts

The App enables you to quickly switch among accounts when you have set multiple accounts for different products.

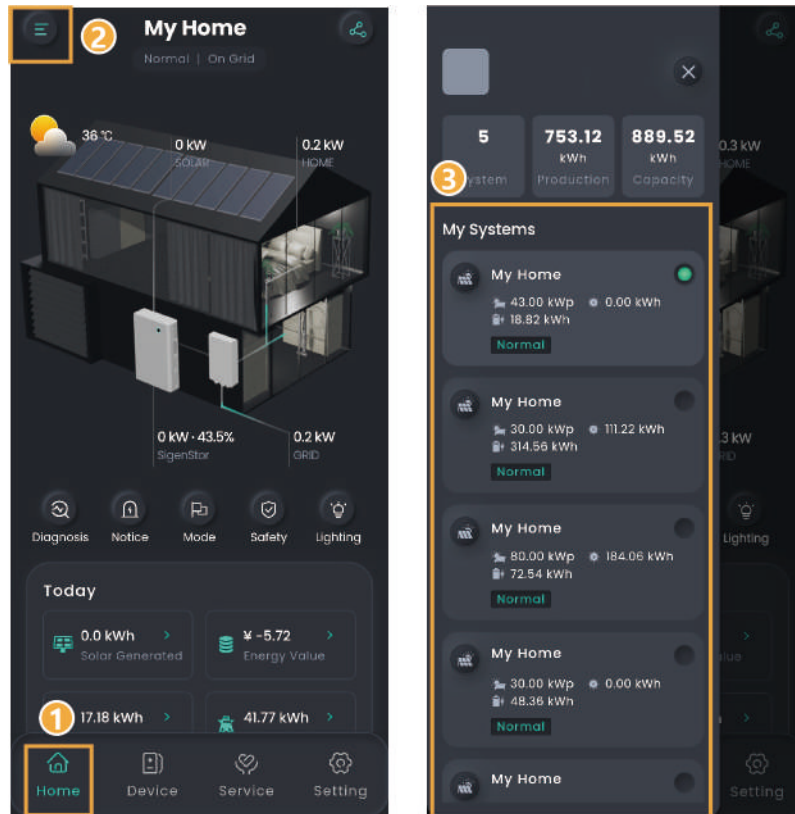

SSA1CM00063

Changing password

Method 1:

On the login screen, click "Forgot Password" to reset the login password.

Method 2:

Click "Setting" and  on the screen top to change "Password."

Changing nickname

Click "Setting" and  on the screen top to modify "Nickname".

Changing binding information

Click "Setting" and  on the screen top to change "Binding Information," for example, email address.

Chapter 8 Setting&Tools

Tips

The configurable parameters under the "Settings & Tools" interface vary depending on the device. Please refer to the actual interface in the App.

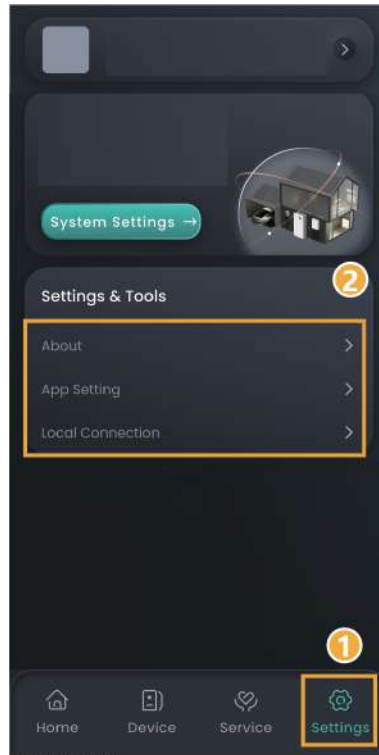

MSA1CM00071

No.	Parameter name	Description
1	About	<p>Tips</p> <p>To gain the best compatibility and performance, you are advised to upgrade the mySigen App regularly.</p> <ul style="list-style-type: none"> ● Tap "Settings" → "About" to view the App software version. ● Tap "Settings" → "About" → "Version Update" to upgrade the App software version.
2	App Setting	Click to set parameters related to the App interface display.
3	Local Connection	Click to scan the device QR code, enabling local network configuration or local maintenance functions.

App Setting

No.	Parameter name	Description
1	Theme display	Specifies the display style.
2	Language	Specifies the display language.
3	Date Format	Different regions have different date formats. Click to set the date format.
4	Sunrise/Sunset Time Format	Set a 12-hour system or a 24-hour system.
5	Temperature Unit	<ul style="list-style-type: none"> ● Sets the unit of temperature. ● The unit of temperature commonly used in the local area is set by default. You can change this setting when needed.
6	Notification	<p>Sets the App push notification permission.</p> <p>This permission is set while the App is installed. You can make settings when needed.</p>
7	Lab	<p>Sets the access permission of Sigen AI.</p> <p>When the parameters are set, if you want to learn about product knowledge, you can inquire in Sigen AI.</p>
8	Diagnostic tool	If an exception occurs when you use the App, you can use this tool to generate operation logs and report to our customer support for analysis and solutions.

8.1 Local Connection



Tips

Scan the SN code label on the accompanying materials. If it is lost, scan the SN code on the side of the inverter.

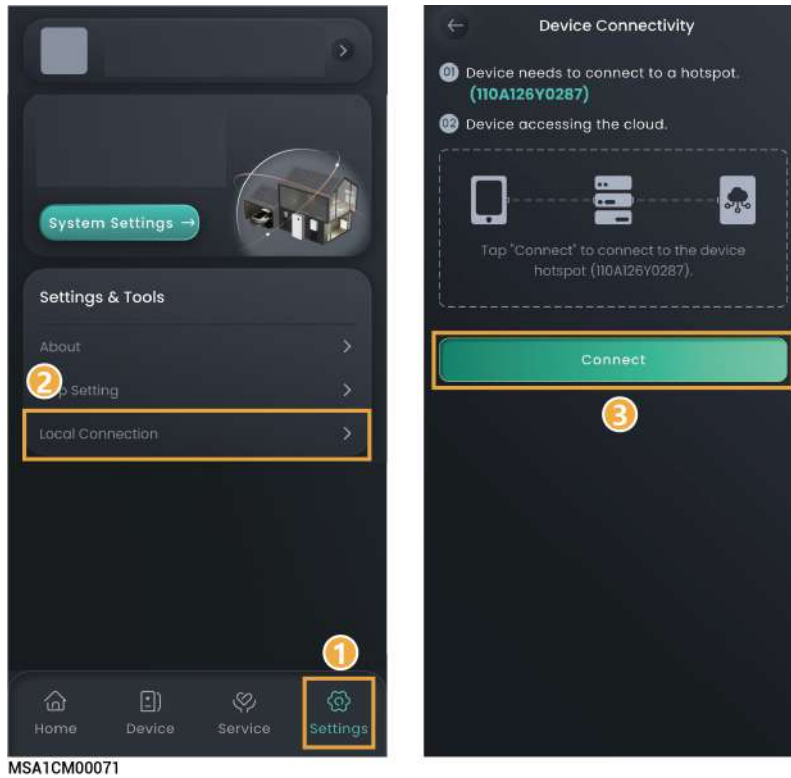
Local device network configuration



No.	Parameter name	Description
1	DNS Settings	<ul style="list-style-type: none"> ● Primary DNS: Primary DNS server for domain name resolution (non-editable). ● Secondary DNS: Secondary DNS server for domain name resolution (editable). (After configuring this parameter, it takes effect for Ethernet, WLAN, and Cellular.)

No.	Parameter name	Description
2	Ethernet	<p>Display FE connection status.</p> <ul style="list-style-type: none"> ● MAC: Show MAC address. ● Ethernet: <ul style="list-style-type: none"> □ Primary DNS: Primary DNS server for domain name resolution (non-editable). □ Secondary DNS: Secondary DNS server for domain name resolution (editable). (After configuring this parameter, it takes effect for Ethernet, WLAN, and Cellular.) ● Obtain IP address automatically: When set to , IP addresses are obtained automatically. When set to , users need to configure a static IP address. <ul style="list-style-type: none"> □ IP Address: IP Address: FE IP address of the current SigenStor/SigenStack Unit. □ Gateway: Gateway: FE gateway of the current SigenStor/SigenStack Unit. □ Subnet Mask: FE subnet mask of the current SigenStor/SigenStack Unit. ● FE network connection parameters are set to DHCP by default. If you need to modify them, follow these steps: Set "Obtain IP address automatically" to , then modify the parameters.
3	WLAN	<p>Display WLAN connection status.</p> <ul style="list-style-type: none"> ● MAC: Show MAC address. <p>If it shows "Not configured" here, but you intend to use WLAN for network connectivity, please follow the instructions below:</p> <ul style="list-style-type: none"> ● Before configuring WLAN communication, ensure that the antenna is installed on the device. ● Connecting to an unencrypted WLAN may result in network unavailability and is not recommended. ● When the device can only use WLAN for network connectivity, do not switch to other wireless router WLANs. ● Tap "Go Set Up" to configure the WLAN network.
4	Cellular	<p>Display 4G connection status.</p> <p>If it shows "Not Connected" here, but you intend to use 4G for network connectivity, please follow the instructions below:</p> <ul style="list-style-type: none"> ● Before configuring 4G communication, ensure that the Sigen Comm-Mod is inserted. ● When using 4G communication, you can view the current monthly data usage. <p>Cellular Setting Do not configure this parameter unless necessary.</p>

Chapter 9 Logout



MSA1CM00071

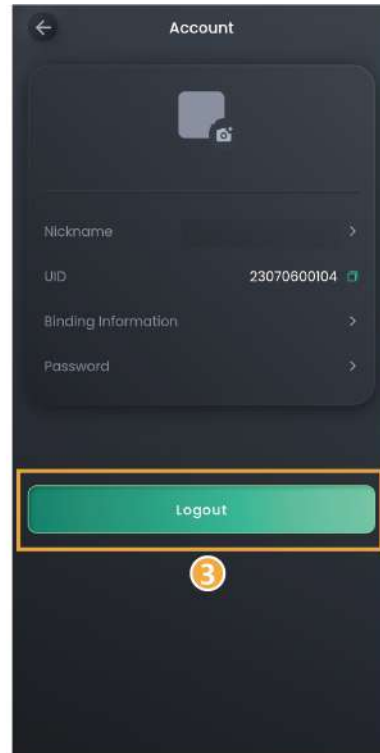

Chapter 10 FAQs

Support

Tips

- To check the question history, click "History" in the upper right corner of the "Support" page.
- Please feel free to reach out to us in the App if you have any questions about the use of the product.

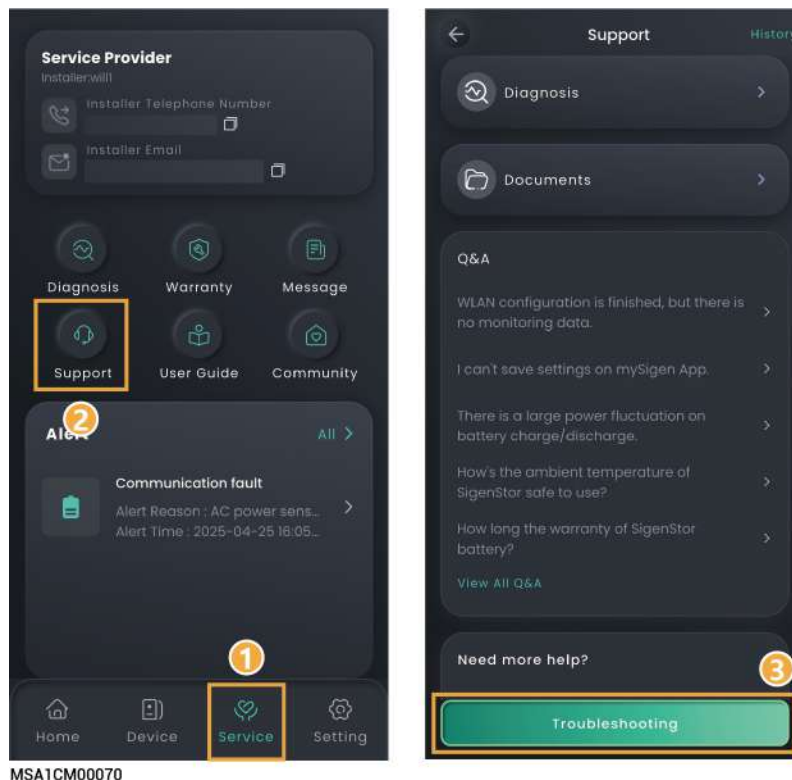

What should I do if I do not receive the email (link, password change) sent by the system?

- Check whether the email from the "sigencloud" account was received in the Spam folder.
- Push the notification again.

What should you do if you want to disconnect WLAN when the communication mode changes from WLAN to FE?

1. Insert the network cable into the device.
2. On the "Home" screen, click the station name you want to set.
3. Click  next to the station name and click "System Settings" → "Connectivity".

4. Wait until "Ethernet" is connected, click "WLAN", and then select any WLAN and enter an invalid password.

How do I connect a power sensor if the RS485_2 port of the inverter is faulty?

You can connect a power sensor to the RS485_1 port of the inverter. You must manually add a power sensor after the cable is properly connected.

Tips

When the RS485_1 port is connected to a power sensor, do not connect other devices simultaneously. Otherwise, the power control may be affected.

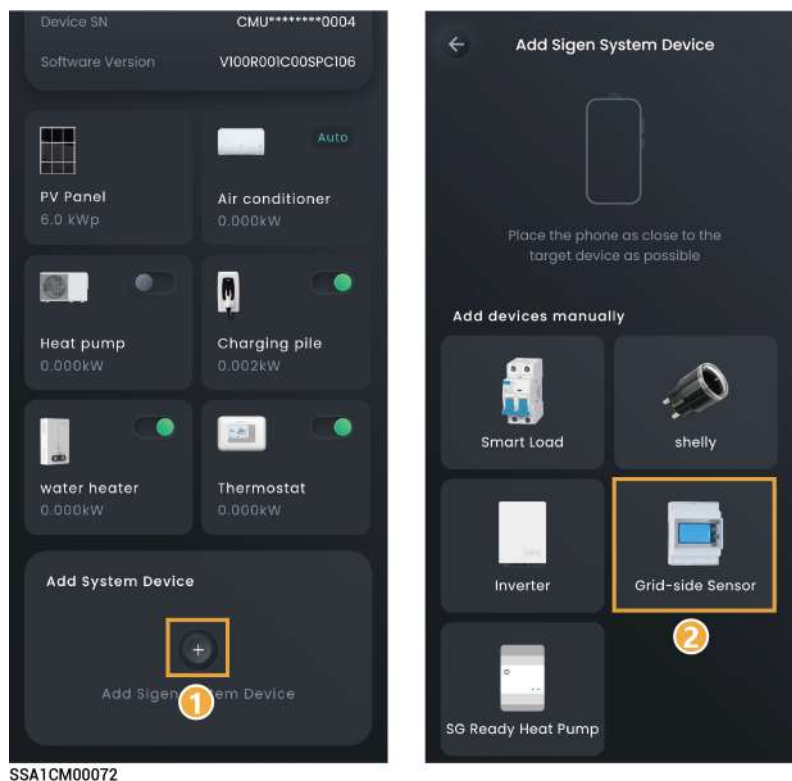

In grid connection scenarios, how can I quickly identify where SigenStor is installed?

You can light up the LED of SigenStor in the App and locate the SigenStor.

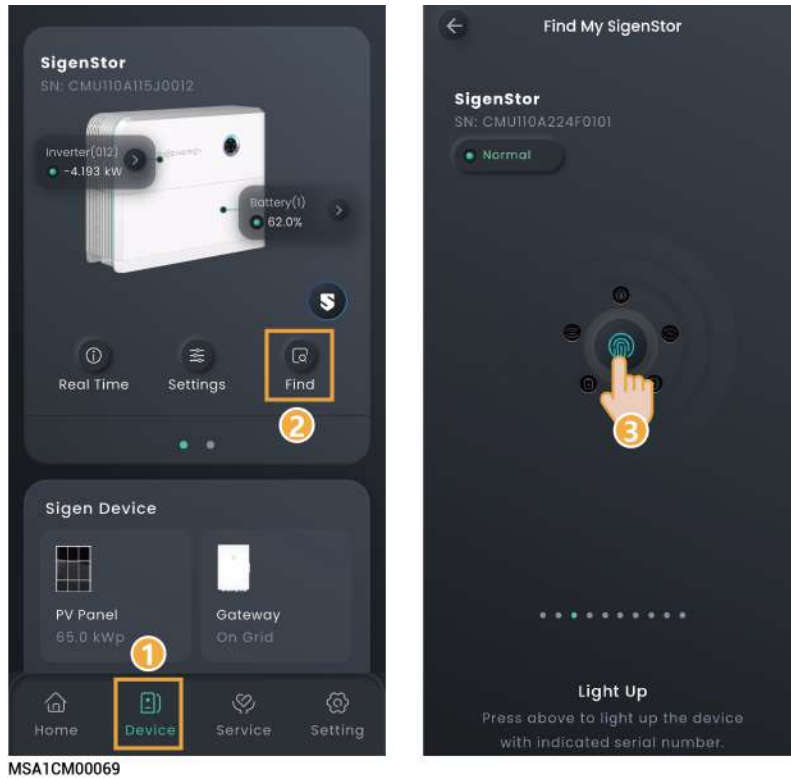

MSA1CM00069

How do I reconnect the network when the device network connection is lost?

You can re-configure the network settings using a device hotspot in "Setting" → "Local Connection" → "Connect"

If you still cannot connect to the device hotspot, disconnect the AC circuit breaker and DC switch of the device, wait for the device indicator to go out, then turn on the AC circuit breaker and DC switch again, wait for 30 seconds, and then rescan the device QR code and configure the network according to the above steps.

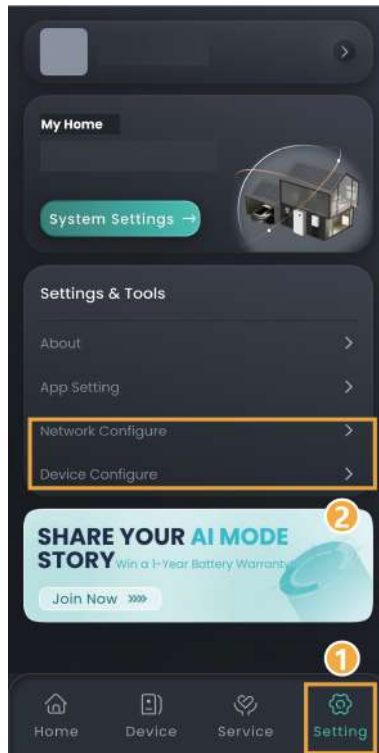

How do I check whether the device is connected in parallel with other ones?

You can check this in "Setting" → "System Affiliation Lookup."

How to recharge the Sigen CommMod data when it is used up?

Method 1:

Click "Service" → "Mall" → "Data Plan" to purchase.

Method 2:

Click "Settings" → "System Settings" → "Connectivity" in General → "Cellular" → "4G Data Recharge"

How to Purchase a License?

- If Sigen Sigen Hybrid SP, Sigen Hybrid SP AU, Sigen Hybrid TP, Sigen Hybrid TP AU, Sigen Hybrid TPLV Series inverters are expected to be applied in PV storage systems, users must purchase and activate the license.
- When upgrading the Sigen EV DC Charging Module (e.g., from 12.5kW to 25kW), it is necessary to purchase and activate a License.
- During purchase, the product information must match the device information.

How to Activate a License?

Click "Service" → "Mall" →  → Select the order to be activated → Click "Activate Now" → Copy the "License Key" → Select power station → Enter the "License Key"

How to Buy Extended Warranty Service?

During purchase, the product information must match the device information.
Click "Service" → "Mall" → "Extended Warranty" to purchase.

How to Activate Extended Warranty Service?

Click "Service" → "Mall" →  → Select the order to be activated → Click "Activate Now" → Copy the "Extended Warranty Key" → Select power station → Enter the "Extended Warranty Key"

How to revoke Sigen View's authorization for accessing power station information?

Click on "Service" → "Community" → "Profile icon" in the upper right corner → "Setting" → "Authorize station info" → "Revoke" → "Unbind" in the upper right corner.

Does the Sigen EV AC Charger (pure charging station) support PV surplus charging with third-party inverters?

Yes, it does. However, the Sigen EV AC Charger pure charging station must be configured with a Sigen power sensor.

How to Return a Completed ticket for Resubmission?

Tickets completed within 7 days can be returned for resubmission.
Click "Service" → "Support" → "History" → Select the ticket → Click "Problem unsolved? Restart ticket"

How to View Power Station Earnings and Income Calendar in Sigen AI Mode?

If the power station has activated Sigen AI mode, Click "Current Mode" on the Homepage → Select "Sigen AI mode" to view the earnings and income calendar for Sigen AI mode.

How to View VPP Dispatch Records in VPP Scheduling Mode?

Click on the power station, scroll down to find the Power Metrics Chart, and click "Grid Service".

How to check the string power of SigenStor in grid connection scenarios

Click "Device" → select "PV Panel" → click " " in the upper right corner → select the corresponding SigenStor SN.

Why are the household load and grid-side power not displayed in the energy flow diagram and statistics for SigenMicro power stations?

SigenMicro power stations are not equipped with a grid connection point meter.

After on-site device commissioning, the customer forgets the password. How to reset the password?

Tips

- The following operations must be completed within 10 minutes of power-on.
- The other end of the Ethernet cable must be connected to a communication-capable device such as a router or laptop.

Operation Steps:

1. After the inverter is powered on, wait for more than 60 seconds.
2. Select an Ethernet port, insert the Ethernet cable, and then remove the cable after more than 1 second.
3. Wait until the communication LED turns solid orange, then insert the Ethernet cable.
4. Wait until the communication LED turns off, then remove the Ethernet cable.
5. Wait until the communication LED turns solid orange, then insert the Ethernet cable.
6. Wait until the communication LED turns off, then remove the Ethernet cable.
7. Wait until the communication LED turns solid orange, then insert the Ethernet cable.
8. Wait until the communication LED turns off. The password has been successfully reset.
9. After a successful reset, scan the QR code to set a new password.